



# BUSBAR TRUNKING SYSTEMS

HP-K SERIES  
400A-6300A

The smartest way of power distribution

[www.dtmbusbar.com](http://www.dtmbusbar.com)



Elektrotechnik A.Ş

# HP-K SERIES

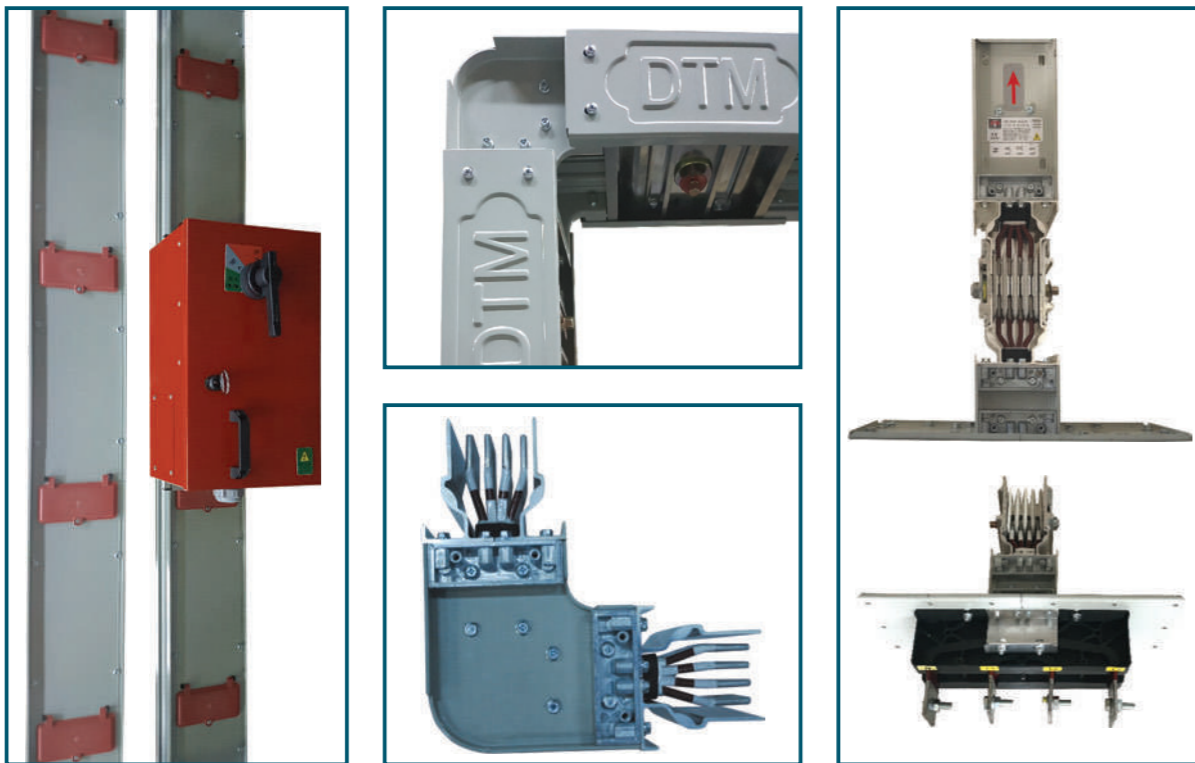

## TABLE OF CONTENTS

<b>General Information</b>	4-7
<b>Project Information</b>	8-11
<b>Fittings</b>	
Straight Lengths	12
Elbow Modules	13-16
Panel Modules	17-20
Tee Modules	21
Expansion Module	22
Dilatation Module	22
Phase Transposition Module	22
Reduction Module	22
Transformer Module	23-25
Flanged End	25
Feeder Boxes	26-27
Tap-Off Units (Bolt-On)	28-29
Tap-Off Units (Plug-In)	30-31
<b>Technical Data</b>	
Product Features	32-34
Flexible Connection	35
Panel Bellows Flange	36
<b>Hanger Kit</b>	
Hangers	37-45
<b>Information on Measuring Busbars</b>	
Technical Tables	46-52
Information on Measuring Busbars	53
<b>Installation Information</b>	
Kit Installation	54-55
<b>Quality Certificates</b>	
Certificates	56-57
Dimensioning Template	58-59

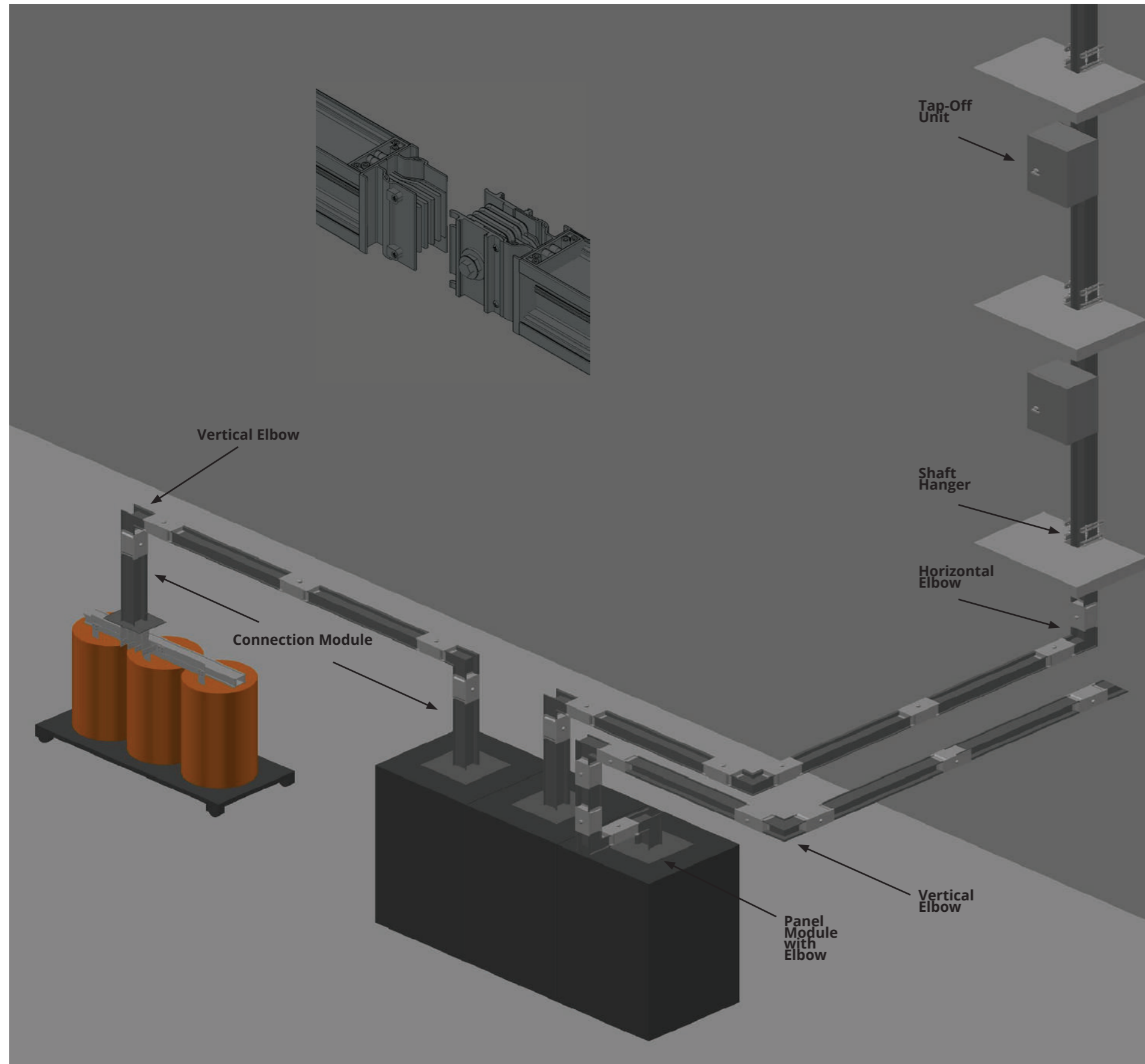

**General Information**

DTM's HP-K Busbar Trunking System is designed as a sandwich construction that is compatible with complicated low voltage power distribution lines. Feeder and Plug-In types allow for easy joining operations. They offer efficiency in low voltage systems in industrial and commercial applications. Feeder and Plug-In are manufactured with Copper or Aluminum conductors from 400 amperes to 6300 amperes. In the 3-pole or 4-pole full neutral configuration, operating voltage is 1000 V. A standard 3P+N+PE housing is 50% of the phase earthing conductor. The enclosure is made of aluminum. The degree of protection is IP 55. However, IP 65 is available upon request.

**Area of Use**

Places with high current requirements such as between the transformer and the panel, high service buildings, trade centers, industrial plants, military establishments, public buildings, etc.

Feeder and Plug-In busbars have a sandwich construction, making installation easier. This construction keeps voltage drop characteristics at minimum and provides regular low reactive power factor. Construction ducts are made of aluminum profile, while top and bottom covers are designed as aluminum. Hysteresis currents and Eddy currents are minimized by means of diffusion inside the duct made of aluminum. In Feeder and Plug-In lengths, if 2 or 3 conductors are used for 1 phase, paralleling is performed at the end of each phase. (In case of phase conductor changes) It helps installing a tap-off unit to one side of the busbar and distributing the load of the busbar equally. The housing of a Plug-In length is equipped with covered windows that allow for straight installation and tap-off outlet. The joint accessories which are used for Feeder types are also suitable for use in Plug-In types. Plug-In and Feeder types can be assembled to each other.

**Fully Closed Construction**

DTM's HP-K Busbar Trunking System is designed as a fully closed system. This duct construction does not lower electrical values. Since there are no vent holes, its conductors do not contact with any foreign objects. The housing is close to the conductors. As a result, heat dissipates directly.

**Paint**

RAL 7038

DTM's HP-K Busbar Trunking System is epoxy coated.

**Insulation and Product Features**

All busbars are epoxy resin coated. The surface of all joints is tin plated for low contact resistance and surface corrosion minimization. Optionally, joint block conductors can be plated with silver.

**Affordable**

Compared to a cable trunking system, DTM's HP-K Busbar Trunking System saves more space and has a lower installation cost.

► Busbar Features

**Voltage Drop**

Thanks to the compact structure, reactance is considerably low, minimizing voltage drop and ensuring the transmission of power in the most efficient way. The cross section of the neutral conductor is same as that of the phase conductor. The cross section of the enclosure used for earthing is larger than that of the phase conductor.

**Joints**

In external feeder busbars, all joints are sealed in order to stop rain water, offering protection and smoothness under all conditions.

**Fittings**

Elbows can be easily attached to the joint block.

**Plug-Ins**

Plug-ins are flameproof (V2) and resistant to adverse ambient conditions and high temperatures. They also resist to severe impacts. The degree of protection of the sealed protective cover, which is made of flame-retardant material, is IP 55. The pressure of the dovetail on the contact surface ensures permeability at spring level.

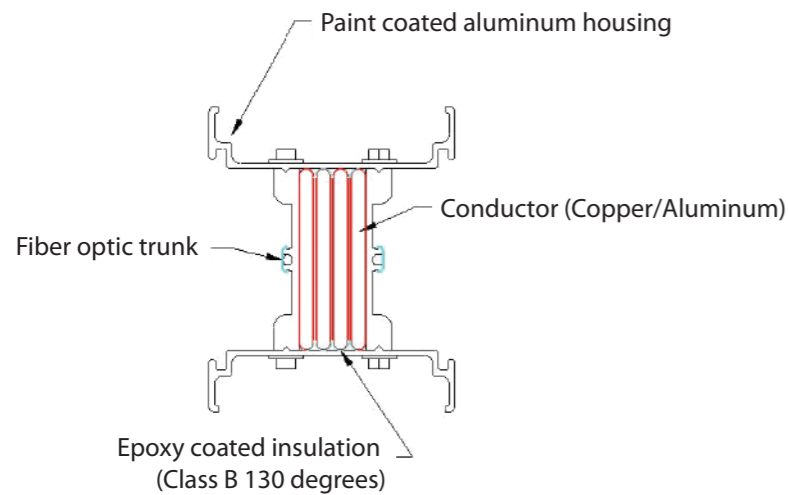

	Products	
	AL	CU
400A	✓	✓
500A	✓	✓
630A	✓	✓
800A	✓	✓
1000A	✓	✓
1250A	✓	✓
1350A	✓	✓
1600A	✓	✓
2000A	✓	✓
2250A	✓	✓
2500A	✓	✓
2000A	✓	✓
2500A	✓	✓
3000A	✓	✓
3200A	✓	✓
3300A	✓	✓
3600A	✓	✓
4000A	✓	✓
4250A	✓	✓
5000A	✓	✓
6300A	-	✓
✓	Standard Production	

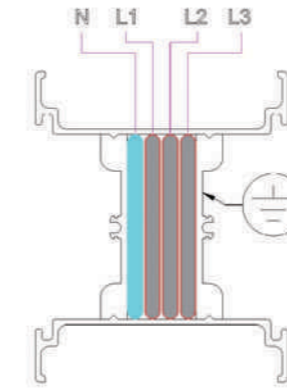

**3P+N+PE (Housing) (4P) (T2)**

The cross section of the neutral conductor is same as that of the phase conductor. The cross section of the enclosure used for earthing is larger than that of the phase conductor.

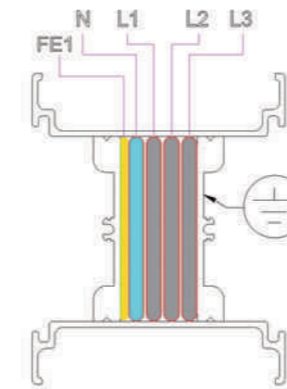

**3P+N+FE1+PE (Housing) (5P) (T3)**

The cross section of the neutral conductor is same as that of the phase conductor. The cross section of the earthing conductor is 1/2 of the neutral conductor. They are put into the same enclosure.

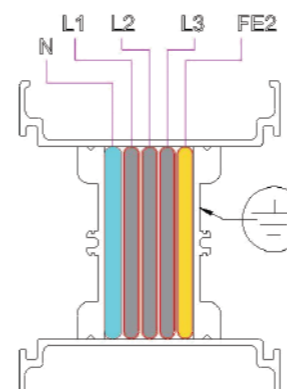

**3P+N+FE2+PE (Housing) (5P) (T4)**

The cross section of the neutral conductor is same as that of the phase conductor and that of the earthing conductor. They are put into the same enclosure.

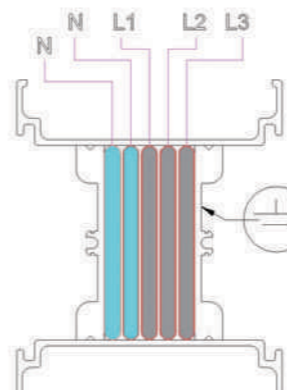

**3P+2N+PE (Housing) (5P) (T5)**

The cross section of the neutral conductor is same as or twice that of the phase conductor.

► Busbar Trunking System Selection

**Ambient Conditions**

- Interior Installation .....
- Exterior Installation .....
- With Roof .....  Without Roof .....
- Minimum Air Temperature Interior ..... °C
- Exterior ..... °C
- Maximum Air Temperature Interior ..... °C
- Exterior ..... °C
- Air Temperature Average of 24 Hours Interior ..... °C
- Exterior ..... °C
- Humidity Rate Min ..... °C
- Max ..... °C
- Country of Installation .....

**Electrical Data**

- Nominal Current ..... A
- Starting Current ..... A
- Phase Poles 3P+Pe
- 3P+N+Pe
- 3P+Pen
- 3P+2N+Pe
- 3P+N+Fe/2+Pe
- 3P+N+Fe+Pe
- Operating Voltage ..... V
- AC  DC
- Phase Short Circuit ..... kA (1s)
- Max. Voltage Drop ΔV ..... %
- Minimum Degree of Protection IP .....
- Conductor Metals AL  Copper

**Busbar Types**

- Feeder Busbar Transformer-to-Panel
- Feeder Busbar Panel-to-Panel
- Feeder Busbar Generator-to-Panel
- Plug-In Busbar Tap-Off Units
- Busbar Total Length .....
- Feeder ..... m
- Plug-in ..... m
- Elbows ..... m

**Connection**

- Between Busbar and Panel Yes  No
- Between busbar and transformer Yes  No
- Transformer Resin Yes  No
- Transformer Features Yes  No

**Tap-Off Units**

- Empty, With Fuse Base
- With Fuse Base, Fuse Switch Disconnecter
- With Automatic Switch, Empty
- With Automatic Switch

**Hanger Kits**

- Ceiling Hanger Bracket  Wall Hanger Bracket

**Busbar Types**

- Fire Barrier Unit ..... min.

Elbow preliminary and isometric drawings for fittings.  
Please draw the project detail dimensions as shown in the example.

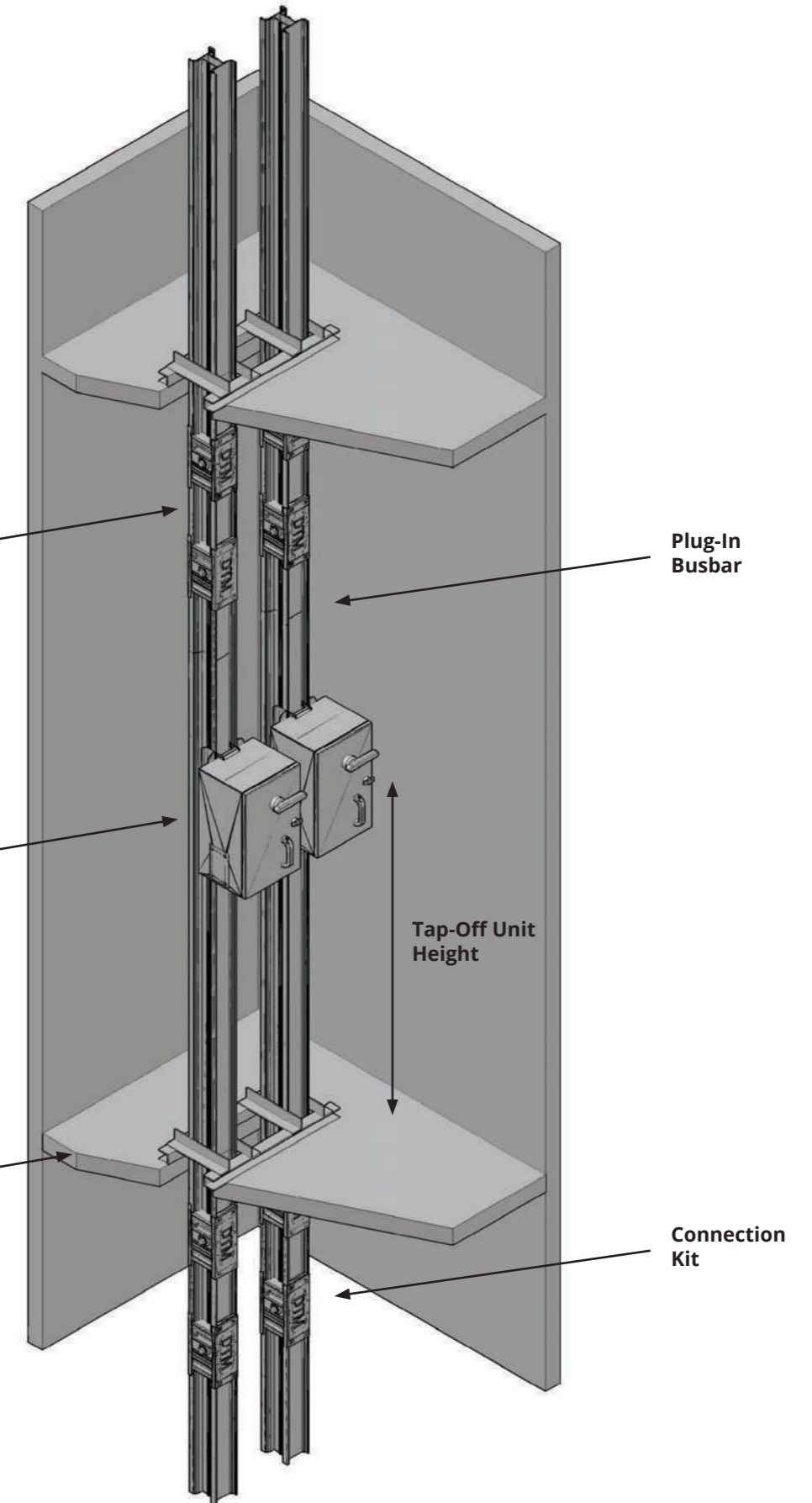
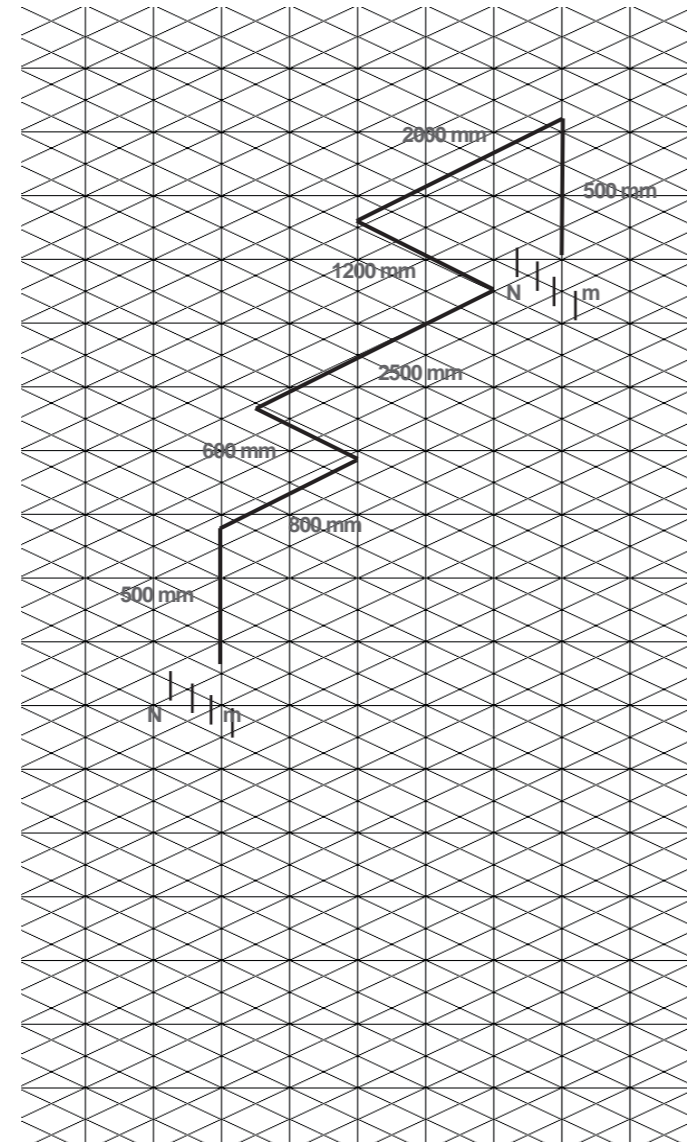

Vertical Distribution Project

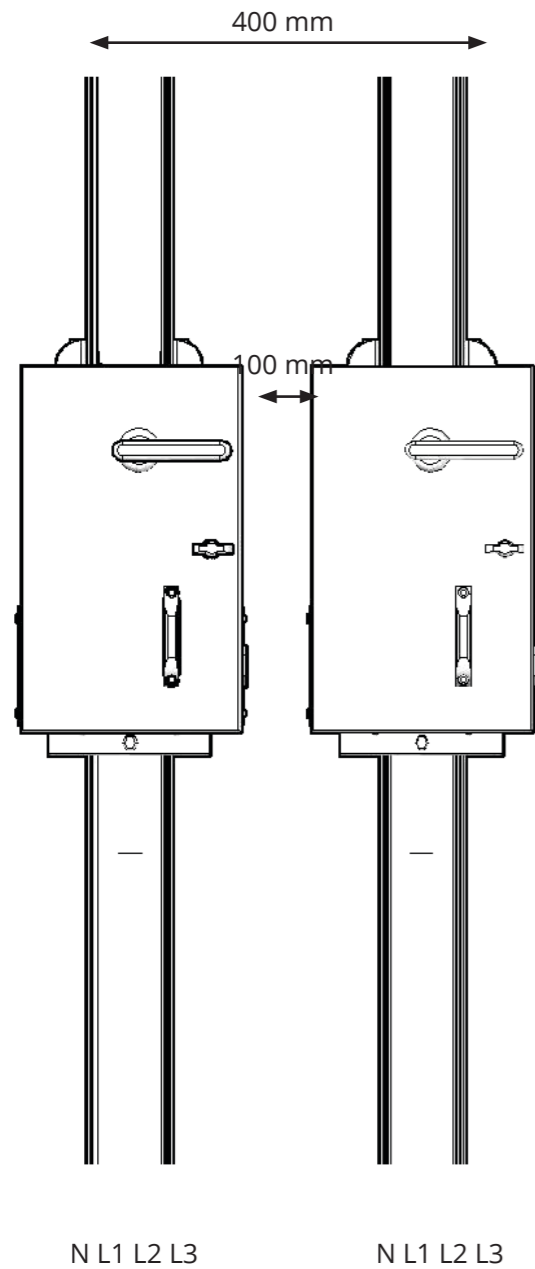

H = Concrete Thickness (cm ?)  
W = Floor Height (cm ?)

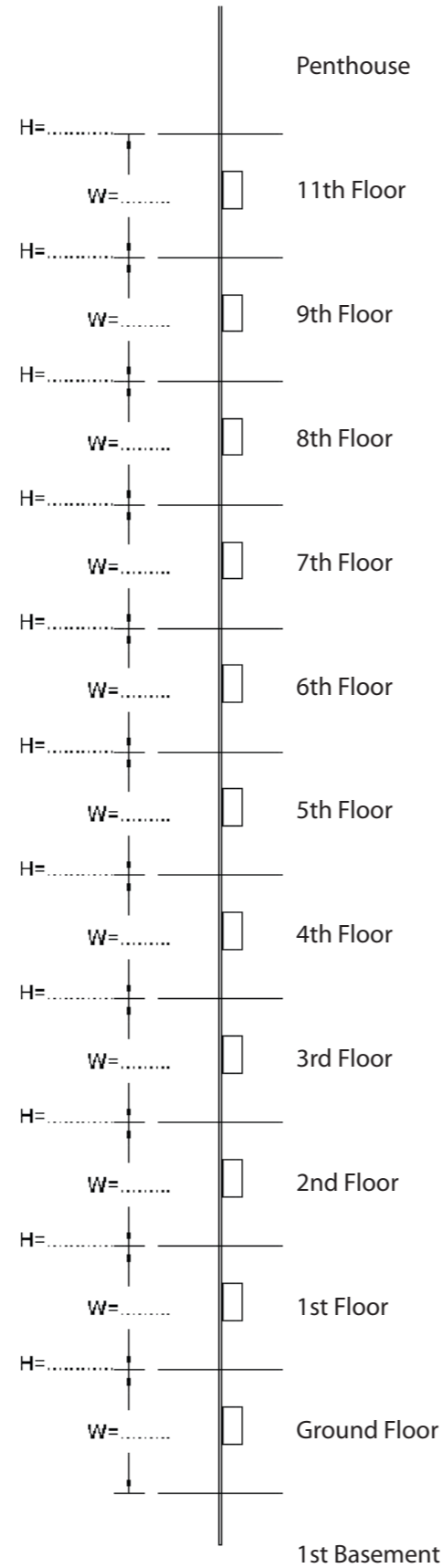

Order Code System

Order Code System

HP-K A 08 5 T2 F DDR

Busbar Type: HP-K

Conductor Type: ALUMINIUM (AL) (A)

Busbar Code: 08

Degree of Protection: IP55

Number of Conductors: 5

Type P-Plug-In/F-Feeder: F

Module Name: DDR

CURRENT	BUSBAR CODE	CURRENT	BUSBAR CODE
400	04	550	05
500	05	650	06
630	06	800	07
800	08	1000	09
-	-	1250	13
1000	10	1350	15
1250	12	1600	17
1350	14	-	-
-	-	2000	21
1600	16	-	-
-	-	2250	23
2000	20	2500	24
2500	25	-	-
-	-	2000	22
-	-	2500	27
2500	26	3300	33
-	-	3600	36
3000	30	4000	41
3200	32	-	-
-	-	4250	42
4000	40	5000	51
5000	50	6300	63

NUMBER OF CONDUCTORS	CODE	L1	L2	L3	N	1/2 EARTH	CLEAN EARTH	1/2 CLEAN EARTH	EARTH
3P+PE (3P)	T1	✓	✓	✓					✓
3P+N+PE (4P)	T2	✓	✓	✓	✓				✓
3P+N+PE+FE1 (5P)	T3	✓	✓	✓	✓	✓			✓
3P+N+PE+FE2 (5P)	T4	✓	✓	✓	✓		✓		✓
3P+2N+PE (5P)	T5	✓	✓	✓	✓		✓		✓

Module Name	Code
Feeder Busbar	FS
Plug-In Busbar	PS
Horizontal Elbow Upwards	YDU
Horizontal Elbow Downwards	YDD
Vertical Elbow Left	DDL
Vertical Elbow Right	DDR
Feeder Optional Length	FX
Plug-In Optional Length	PX
Double Vertical Elbow (Off-Set) Upwards	DOU
Double Vertical Elbow (Off-Set) Downwards	DOD
Double Vertical Elbow (Off-Set) Left	YOL
Double Vertical Elbow (Off-Set) Right	YOR
Upwards Left (Combined Off-Set)	ULK
Upwards Right (Combined Off-Set)	URK
Left Downwards (Combined Off-Set)	LDK
Right Downwards (Combined Off-Set)	RDK
Left Upwards (Combined Off-Set)	LUK
Right Upwards (Combined Off-Set)	RUK
Downwards Left (Combined Off-Set)	DLK
Downwards Right (Combined Off-Set)	DRK
Centre Tee Module	OT
Right Tee Module	RT
Right Tee Module	LT
Reduction	RD
Expansion Module	G
Panel Connection Module (E)	PME
Panel Connection Module (D)	PMD
Panel Vertical Connection Module Upwards	PM1
Panel Vertical Connection Module Downwards	PM2
Panel Vertical Connection Module Upwards	PM3
Panel Vertical Connection Module Downwards	PM4
Panel Horizontal Connection Module Left	PM5
Panel Horizontal Connection Module Right	PM6
Panel Horizontal Connection Module Left	PM7
Panel Horizontal Connection Module Right	PM8
With Mechanism (Plug-In)	HPP
With Compact Switch (Plug-In)	HPS
With Compact Switch (Bolt-On)	HPB
With Mechanism (Bolt-On)	HPM
Vertical Transformer Module	TR1
Upwards Transformer Module	TRU
Downwards Transformer Module	TRD
Right Transformer Module	TRR
Left Transformer Module	TRL
Horizontal Transformer Connection Module	TMH
Horizontal Transformer Connection Module	TMF
Horizontal Transformer Connection Module Centre	TMO
Top Feed Module	BM1
Top Feed Module	BM2
Centre Feed Module	OB
Phase Transposition Module	CM
Flanged End	S1
Horizontal Dilatation	YD
Horizontal Hanger Vertical Module (Custom)	YVA
Wall Hanger Kit (Horizontal)	DYA
Horizontal Hanger Vertical Module (U Profile)	YVU
Horizontal Hanger Horizontal Module (U Profile)	YHU
Horizontal Hanger Vertical Module (45x65 Bracket)	YUD
Horizontal Hanger Horizontal Module (45x65 Bracket)	YUY
Shaft Hanger Module (Spring)	SA
Horizontal Panel Module Inlet	YP1
Horizontal Panel Module Outlet	YP2
Flanged End	S2
Horizontal Hanger Vertical Module (50x50 Bracket)	YLD
Horizontal Hanger Vertical Module (45x65 Bracket)	YLY
Horizontal Hanger Horizontal (U) Profile Module	YUP
Horizontal Ceiling Connection Kit	YTK
Flexible Connection Busbar	FB
Panel Bellows Flange	PKF

Type: Information about the Busbar's Intended Use

(P) PLUG-IN  
USED FOR RECEIVING CURRENT FROM PLUG-IN POINTS IN STRAIGHT LENGTHS

(F) FEEDER  
USED IN DIRECT SUPPLY POINTS

Type P-Plug-In/F-Feeder

### Standard Length

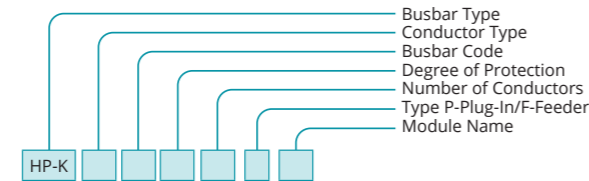
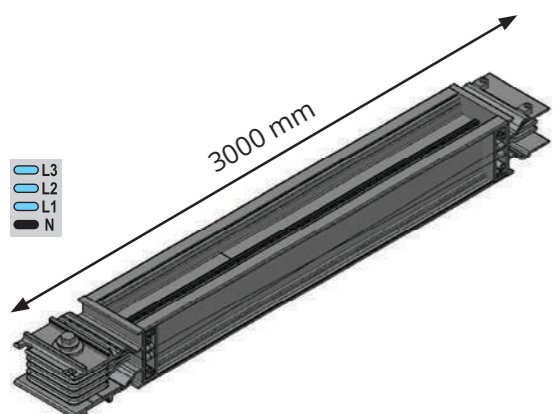
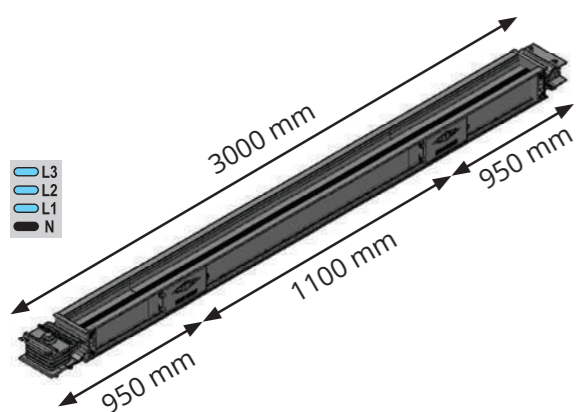
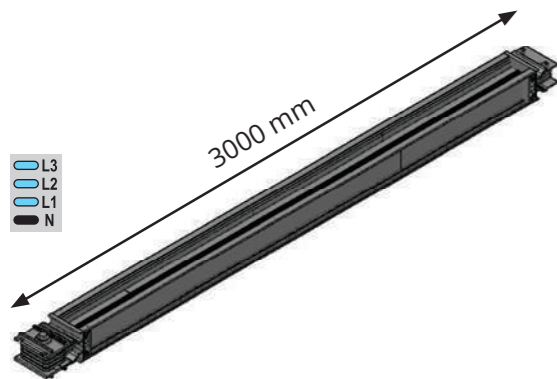

Feeder Busbar FS

#### SAMPLE ORDER

1600 A Aluminum,  
Feeder IP 55 4 Conductor  
**HP-KA165T2FS**

**FEEDER BUSBAR**  
It allows for direct supply in power transmission. It is possible to draw current through the bolt-on. As a standard, it is 3000 mm. However, upon request, it can be manufactured in different sizes starting from minimum 500 mm.

Plug-in Busbar PS

#### SAMPLE ORDER

1250 A Aluminum,  
Plug-In IP 55 4 Conductor  
**HP-KA125T2PS**

**PLUG-IN BUSBAR**  
In plug-in lengths, it is manufactured with two tap-off points. The number of tap-off points can be increased/decreased upon request.  
In plug-in busbars, it is possible to draw current up to 1000 A from the joints with bolt-on tap-off units and up to 630 A from the sockets with plug-in tap-off units.  
**Note:** Please indicate the number of windows (for drawing current) and the number of directions (one-way/two-way) in your plug-in busbar purchase order.

Feeder Busbar Optional Length FX

#### SAMPLE ORDER

2000 A Aluminum,  
Feeder IP 55 4 Conductor  
**HP-KA205T2FX**

**Note:**  
Feeder Minimum Optional Length = 50 cm  
Plug-In Minimum Optional Length = 100 cm

▶ Please contact us for custom-length modules.

### Elbow Modules

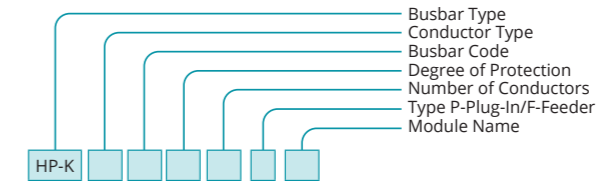
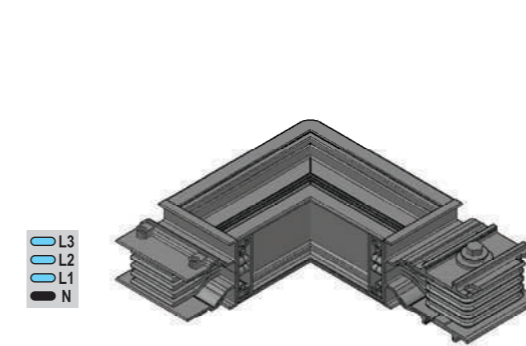
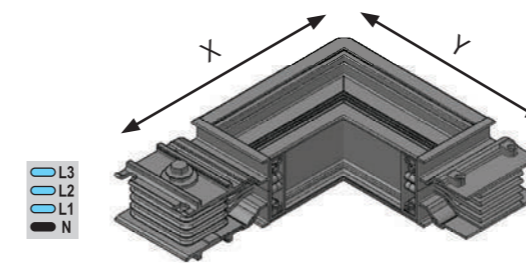
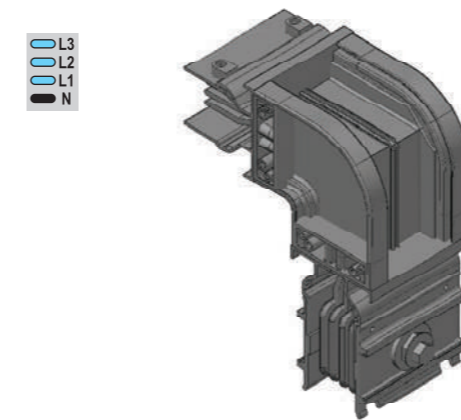
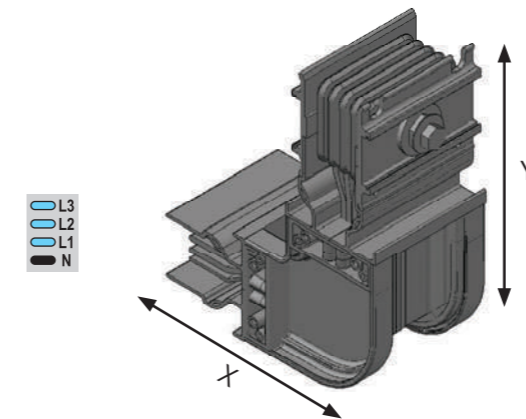

Vertical Elbow Left DDL

#### SAMPLE ORDER

800 A Aluminum,  
Elbow IP 55 4 Conductor  
**HP-KA085T2FDDL**

Vertical Elbow Right DDR

#### SAMPLE ORDER

3200 A Aluminum,  
Elbow IP 55 4 Conductor  
**HP-KA325T2FDDR**

Horizontal Elbow Upwards YDU

#### SAMPLE ORDER

4250 A Aluminum,  
Elbow IP 55 4 Conductor  
**HP-KA425T2FYDU**

Horizontal Elbow Downwards YDD

#### SAMPLE ORDER

800 A Aluminum,  
Elbow IP 55 4 Conductor  
**HP-KA085T2FYDD**

▶ Please contact us for custom-length modules.

VERTICAL ELBOW					
It is used for turning upwards or downwards in the vertical installation of busbar runs.					
(AL)			(CU)		
AMR.	W mm	T mm	AMR.	W mm	T mm
400A	230	230	550A	230	230
500A	230	230	650A	230	230
630A	230	230	800A	230	230
800A	230	230	1000A	230	230
1000A	230	230	1250A	230	230
1250A	230	230	1350A	230	230
1350A	230	230	1600A	230	230
1600A	230	230	2000A	230	230
2000A	230	230	2250A	230	230
2500A	230	230	2500A	230	230
2500A	230	230	2000A	230	230
3000A	230	230	2500A	230	230
3200A	230	230	3300A	230	230
4000A	230	230	3600A	230	230
5000A	230	230	4000A	230	230
			4250A	230	230
			5000A	230	230
			6300A	230	230

HORIZONTAL ELBOW					
It is used for turning right or left in the horizontal installation of busbar runs.					
(AL)			(CU)		
AMR.	W mm	T mm	AMR.	W mm	T mm
400A	248	248	550A	248	248
500A	248	248	650A	248	248
630A	248	248	800A	248	248
800A	255	255	1000A	255	255
1000A	268	268	1250A	263	263
1250A	283	283	1350A	268	268
1350A	290	290	1600A	283	283
1600A	308	308	2000A	298	298
2000A	328	328	2250A	308	308
2500A	353	353	2500A	328	328
2500A	342	342	2000A	302	302
3000A	387	387	2500A	328	328
3200A	407	407	3300A	357	357
4000A	447	447	3600A	372	372
5000A	565	565	4000A	387	387
			4250A	407	407
			5000A	447	447
			6300A	565	565

### Elbow Modules

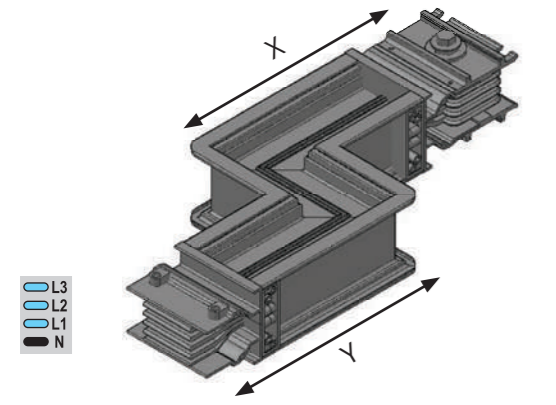
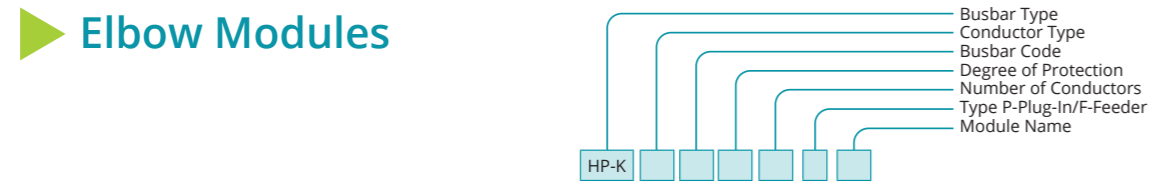

Double Horizontal Elbow Left (Off-Set) YOL

**SAMPLE ORDER**  
1000 A Aluminum, Off-Set IP 55 4 Conductor  
**HP-KA105T2FYOL**

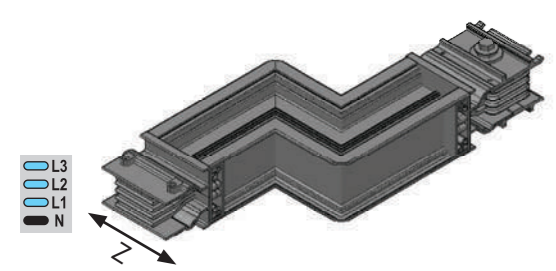

Double Horizontal Elbow Right (Off-Set) YOR

**SAMPLE ORDER**  
1600 A Aluminum, Off-Set IP 55 4 Conductor  
**HP-KA165T2FYOR**

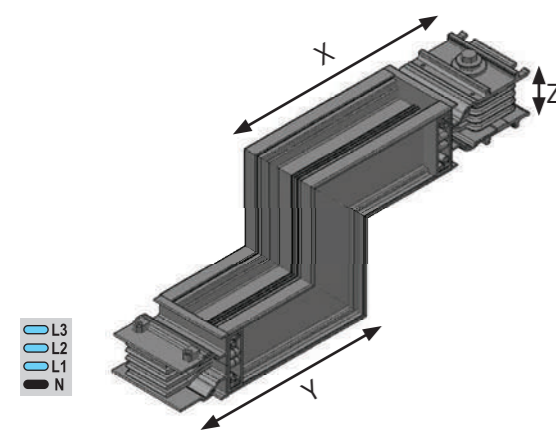

Double Vertical Elbow Upwards (Off-Set) DOU

**SAMPLE ORDER**  
2500 A Aluminum, Off-Set IP 55 4 Conductor  
**HP-KA255T2FDOU**

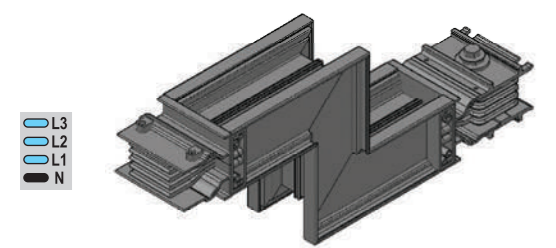

Double Vertical Elbow Downwards (Off-Set) DOD

**SAMPLE ORDER**  
3000 A Aluminum, Off-Set IP 55 4 Conductor  
**HP-KA305T2FDOD**

**DOUBLE HORIZONTAL ELBOW (OFF-SET)**  
It is used for turning right or left (with offset) in the horizontal installation of busbar runs.

(AL)				(CU)			
AMR.	X mm	Y mm	Z mm	AMR.	X mm	Y mm	Z mm
400A	248	248	248	550A	248	248	248
500A	248	248	248	650A	248	248	248
630A	248	248	248	800A	248	248	248
800A	255	255	255	1000A	255	255	255
1000A	268	268	268	1250A	263	263	263
1250A	283	283	283	1350A	268	268	268
1350A	290	290	290	1600A	283	283	283
1600A	308	308	308	2000A	298	298	298
2000A	328	328	328	2250A	308	308	308
2500A	353	353	353	2500A	328	328	328
2500A	342	342	342	2000A	302	302	302
3000A	387	387	387	2500A	328	328	328
3200A	407	407	407	3300A	357	357	357
4000A	447	447	447	3600A	372	372	372
5000A	565	565	565	4000A	387	387	387
				4250A	407	407	407
				5000A	447	447	447
				6300A	565	565	565

**DOUBLE VERTICAL ELBOW (OFF-SET)**  
It is used for turning upwards or downwards (with offset) in the vertical installation of busbar runs.

(AL)				(CU)			
AMR.	X mm	Y mm	Z mm	AMR.	X mm	Y mm	Z mm
400A	230	230	250	550A	230	230	250
500A	230	230	250	650A	230	230	250
630A	230	230	250	800A	230	230	250
800A	230	230	250	1000A	230	230	250
1000A	230	230	250	1250A	230	230	250
1250A	230	230	250	1350A	230	230	250
1350A	230	230	250	1600A	230	230	250
1600A	230	230	250	2000A	230	230	250
2000A	230	230	250	2250A	230	230	250
2500A	230	230	250	2500A	230	230	250
2500A	230	230	250	2000A	230	230	250
3000A	230	230	250	2500A	230	230	250
3200A	230	230	250	3300A	230	230	250
4000A	230	230	250	3600A	230	230	250
5000A	230	230	250	4000A	230	230	250
				4250A	230	230	250
				5000A	230	230	250
				6300A	230	230	250

### Elbow Modules

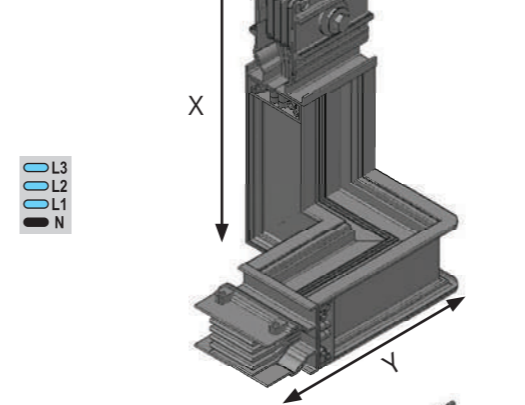
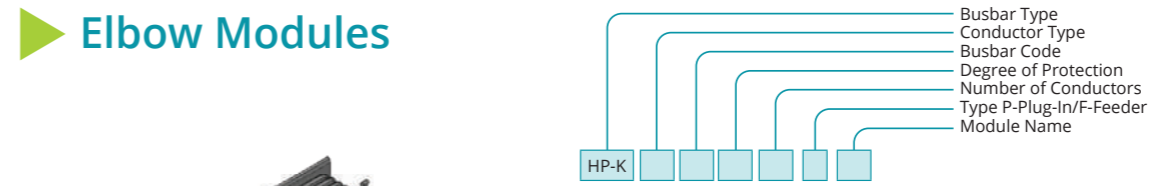

Left Upwards (Combined Off-Set) LUK

**SAMPLE ORDER**  
1250 A Aluminum, Combined Off-Set IP 55 4 Conductor  
**HP-KA125T2FLUK**

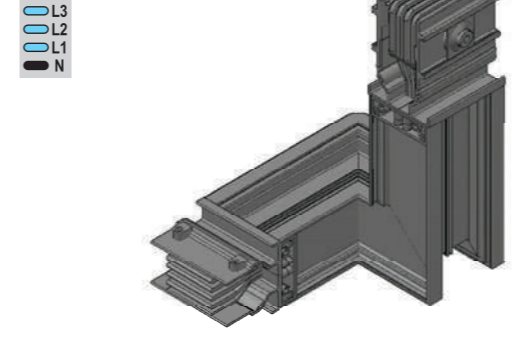

Right Upwards (Combined Off-Set) RUK

**SAMPLE ORDER**  
1000 A Aluminum, Combined Off-Set IP 55 4 Conductor  
**HP-KA105T2FRUK**

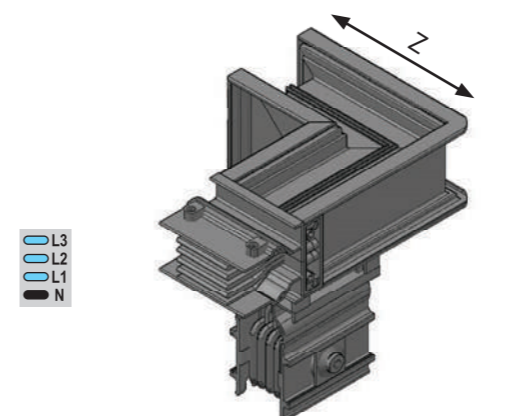

Left Downwards (Combined Off-Set) LDK

**SAMPLE ORDER**  
1600 A Aluminum, Combined Off-Set IP 55 4 Conductor  
**HP-KA165T2FLDK**

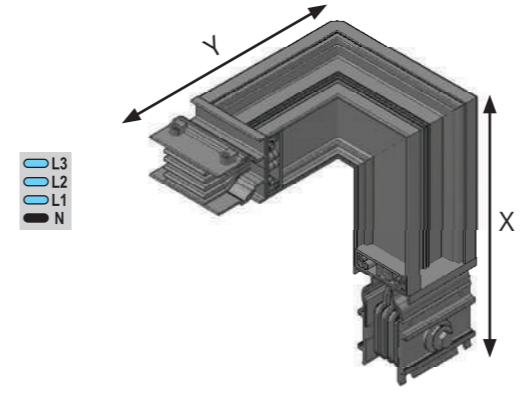

Right Downwards (Combined Off-Set) RDK

**SAMPLE ORDER**  
1350 A Aluminum, Combined Off-Set IP 55 4 Conductor  
**HP-KA145T2FRDK**

**RIGHT/LEFT UPWARDS COMBINED (OFF-SET)**  
It is used for turning right or left (with offset) in the horizontal installation of busbar runs.

(AL)				(CU)			
AMR.	X mm	Y mm	Z mm	AMR.	X mm	Y mm	Z mm
400A	248	248	300	550A	248	248	300
500A	248	248	300	650A	248	248	300
630A	248	248	300	800A	248	248	300
800A	255	255	300	1000A	255	255	300
1000A	268	268	300	1250A	263	263	300
1250A	283	283	300	1350A	268	268	300
1350A	290	290	300	1600A	283	283	300
1600A	308	308	300	2000A	298	298	300
2000A	328	328	300	2250A	308	308	300
2500A	353	353	300	2500A	328	328	300
2500A	342	342	300	2000A	302	302	300
3000A	387	387	300	2500A	328	328	300
3200A	407	407	300	3300A	357	357	300
4000A	447	447	300	3600A	372	372	300
5000A	565	565	300	4000A	387	387	300
				4250A	407	407	300
				5000A	447	447	300
				6300A	565	565	300

**RIGHT/LEFT DOWNWARDS COMBINED (OFF-SET)**  
It is used as right or left for turning busbar runs from horizontal to vertical.

(AL)				(CU)			
AMR.	X mm	Y mm	Z mm	AMR.	X mm	Y mm	Z mm
400A	248	248	300	550A	248	248	300
500A	248	248	300	650A	248	248	300
630A	248	248	300	800A	248	248	300
800A	255	255	300	1000A	255	255	300
1000A	268	268	300	1250A	263	263	300
1250A	283	283	300	1350A	268	268	300
1350A	290	290	300	1600A	283	283	300
1600A	308	308	300	2000A	298	298	300
2000A	328	328	300	2250A	308	308	300
2500A	353	353	300	2500A	328	328	300
2500A	342	342	300	2000A	302	302	300
3000A	387	387	300	2500A	328	328	300
3200A	407	407	300	3300A	357	357	300
4000A	447	447	300	3600A	372	372	300
5000A	565	565	300	4000A	387	387	300
				4250A	407	407	300
				5000A	447	447	300
				6300A	565	565	300

▶ Please contact us for custom-length modules.

▶ Please contact us for custom-length modules.



### Elbow Modules

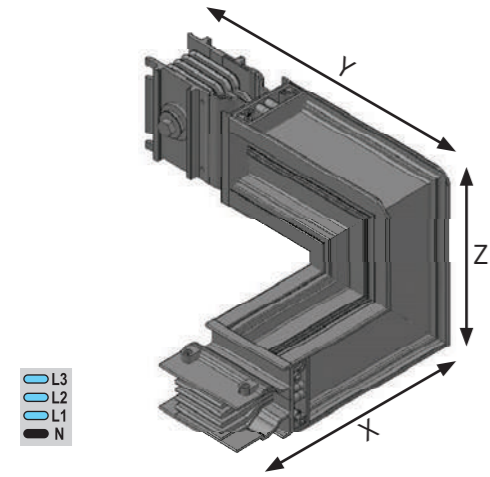

L3  
L2  
L1  
N

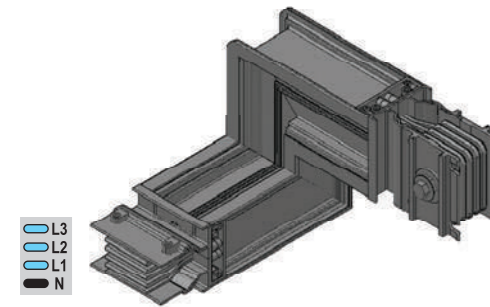

L3  
L2  
L1  
N

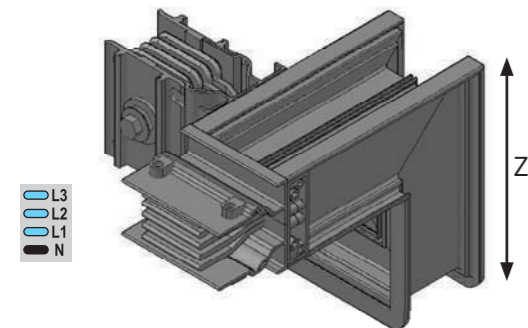

L3  
L2  
L1  
N

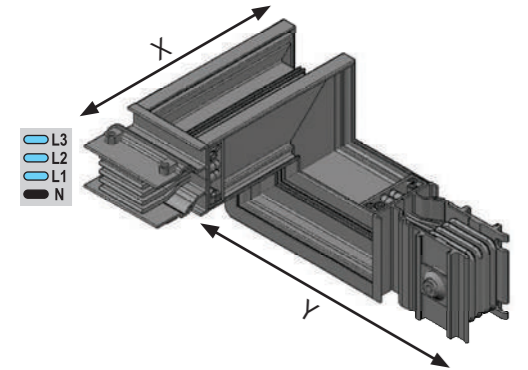

L3  
L2  
L1  
N

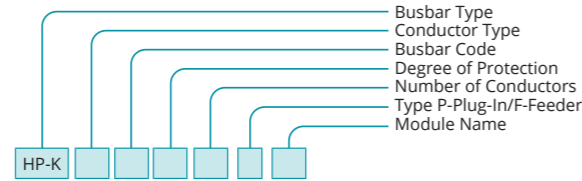

Upwards Left (Combined Off-Set) **ULK**

**SAMPLE ORDER**  
2000 A Copper Combined Off-Set IP 55 4 Conductor  
**HP-KC215T2FULK**

Upwards Right (Combined Off-Set) **URK**

**SAMPLE ORDER**  
1250 A Copper Combined Off-Set IP 55 4 Conductor  
**HP-KC135T2FURK**

Downwards Left (Combined Off-Set) **DLK**

**SAMPLE ORDER**  
1600 A Copper Combined Off-Set IP 55 4 Conductor  
**HP-KC175T2FDLK**

Downwards Right (Combined Off-Set) **DRK**

**SAMPLE ORDER**  
1250 A Aluminum, Combined Off-Set IP 55 4 Conductor  
**HP-KA125T2FDRK**

UPWARDS RIGHT/LEFT COMBINED (OFF-SET)							
It is used as right or left for turning busbar runs from horizontal to vertical.							
(AL)				(CU)			
AMR.	X mm	Y mm	Z mm	AMR.	X mm	Y mm	Z mm
400A	248	248	300	550A	248	248	300
500A	248	248	300	650A	248	248	300
630A	248	248	300	800A	248	248	300
800A	255	255	300	1000A	255	255	300
1000A	268	268	300	1250A	263	263	300
1250A	283	283	300	1350A	268	268	300
1350A	290	290	300	1600A	283	283	300
1600A	308	308	300	2000A	298	298	300
2000A	328	328	300	2250A	308	308	300
2500A	353	353	300	2500A	328	328	300
2500A	342	342	300	2000A	302	302	300
3000A	387	387	300	2500A	328	328	300
3200A	407	407	300	3300A	357	357	300
4000A	447	447	300	3600A	372	372	300
5000A	565	565	300	4000A	387	387	300
				4250A	407	407	300
				5000A	447	447	300
				6300A	565	565	300

DOWNWARDS RIGHT/LEFT COMBINED (OFF-SET)							
It is used as right or left for turning busbar runs from horizontal to vertical.							
(AL)			(CU)				
AMR.	X mm	Y mm	Z mm	AMR.	X mm	Y mm	Z mm
400A	248	248	300	550A	248	248	300
500A	248	248	300	650A	248	248	300
630A	248	248	300	800A	248	248	300
800A	255	255	300	1000A	255	255	300
1000A	268	268	300	1250A	263	263	300
1250A	283	283	300	1350A	268	268	300
1350A	290	290	300	1600A	283	283	300
1600A	308	308	300	2000A	298	298	300
2000A	328	328	300	2250A	308	308	300
2500A	353	353	300	2500A	328	328	300
2500A	342	342	300	2000A	302	302	300
3000A	387	387	300	2500A	328	328	300
3200A	407	407	300	3300A	357	357	300
4000A	447	447	300	3600A	372	372	300
5000A	565	565	300	4000A	387	387	300
				4250A	407	407	300
				5000A	447	447	300
				6300A	565	565	300

### Panel Modules

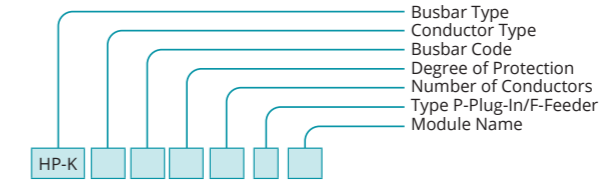

Vertical Panel Module Panel Inlet **PME**

**SAMPLE ORDER**  
1000 A Aluminum, Panel Module IP 55 4 Conductor  
**HP-KA105T2FPME**

Vertical Panel Module Panel Outlet **PMD**

**SAMPLE ORDER**  
1250 A Aluminum, Panel Module IP 55 4 Conductor  
**HP-KA125T2FPMD**

Vertical Panel Module Upwards Panel Inlet **PM1**

**SAMPLE ORDER**  
800 A Copper Panel Module IP 55 4 Conductor  
**HP-KC075T2FPM1**

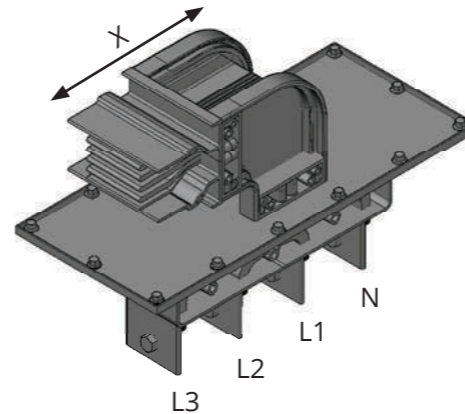
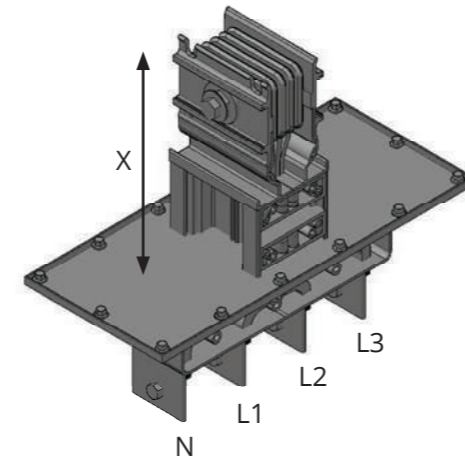
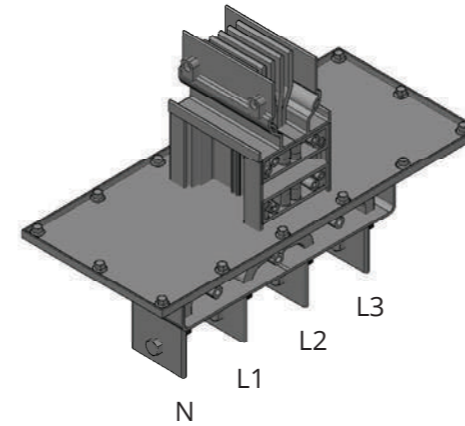

VERTICAL PANEL MODULE			
It is used for connecting straight lengths to the panel.			
(AL)		(CU)	
AMR.	X mm	AMR.	X mm
400A	220	550A	220
500A	220	650A	220
630A	220	800A	220
800A	220	1000A	220
1000A	220	1250A	220
1250A	220	1350A	220
1350A	220	1600A	220
1600A	220	2000A	220
2000A	220	2250A	220
2500A	220	2500A	220
2500A	220	2000A	220
3000A	220	2500A	220
3200A	220	3300A	220
4000A	220	3600A	220
5000A	220	4000A	220
		4250A	220
		5000A	220
		6300A	220

UPWARDS PANEL MODULE					
It is used for connecting straight lengths to the panel.					
(AL)			(CU)		
AMR.	X mm	T mm	AMR.	X mm	T mm
400A	230	230	550A	230	230
500A	230	230	650A	230	230
630A	230	230	800A	230	230
800A	230	230	1000A	230	230
1000A	230	230	1250A	230	230
1250A	230	230	1350A	230	230
1350A	230	230	1600A	230	230
1600A	230	230	2000A	230	230
2000A	230	230	2250A	230	230
2500A	230	230	2500A	230	230
2500A	230	230	2000A	230	230
3000A	230	230	2500A	230	230
3200A	230	230	3300A	230	230
4000A	230	230	3600A	230	230
5000A	230	230	4000A	230	230
			4250A	230	230
			5000A	230	230
			6300A	230	230

▶ Please contact us for custom-length modules.

▶ Please contact us for custom-length modules.

### Panel Modules

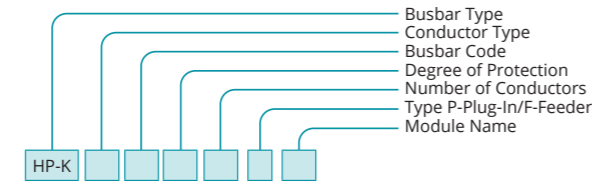
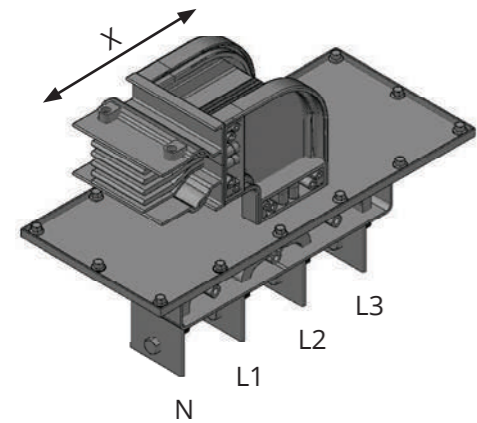

Vertical Panel Module Panel Inlet PM2

**SAMPLE ORDER**  
3000 A Aluminum, Panel Module IP 55 4 Conductor  
**HP-KA305T2FPM2**

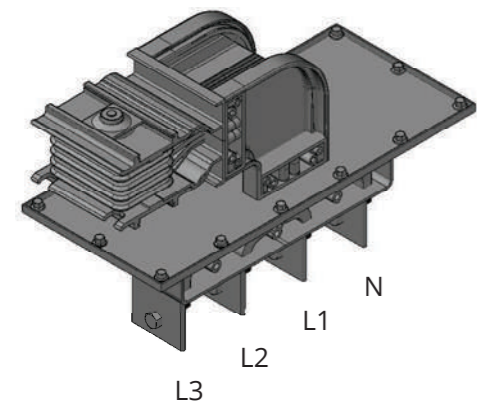

Vertical Panel Module Upwards Panel Outlet PM3

**SAMPLE ORDER**  
4000 A Aluminum, Panel Module IP 55 4 Conductor  
**HP-KA405T2FPM3**

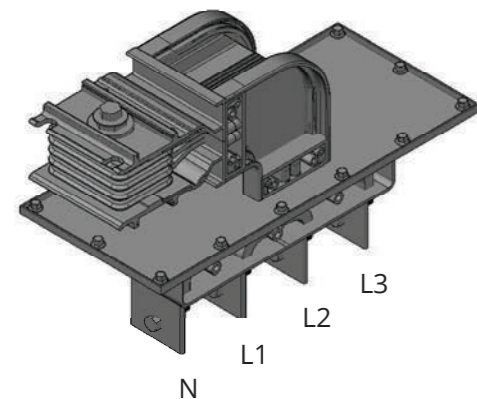

Vertical Panel Module Downwards Panel Inlet PM4

**SAMPLE ORDER**  
1000 A Aluminum, Panel Module IP 55 4 Conductor  
**HP-KA105T2FPM4**

DOWNWARDS PANEL MODULE					
It is used for connecting straight lengths to the panel.					
(AL)			(CU)		
AMR.	X mm	T mm	AMR.	X mm	T mm
400A	230	230	550A	230	230
500A	230	230	650A	230	230
630A	230	230	800A	230	230
800A	230	230	1000A	230	230
1000A	230	230	1250A	230	230
1250A	230	230	1350A	230	230
1350A	230	230	1600A	230	230
1600A	230	230	2000A	230	230
2000A	230	230	2250A	230	230
2500A	230	230	2500A	230	230
2500A	230	230	2000A	230	230
3000A	230	230	2500A	230	230
3200A	230	230	3300A	230	230
4000A	230	230	3600A	230	230
5000A	230	230	4000A	230	230
			4250A	230	230
			5000A	230	230
			6300A	230	230

▶ Please contact us for custom-length modules.

### Panel Modules

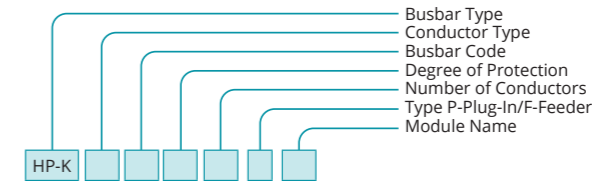
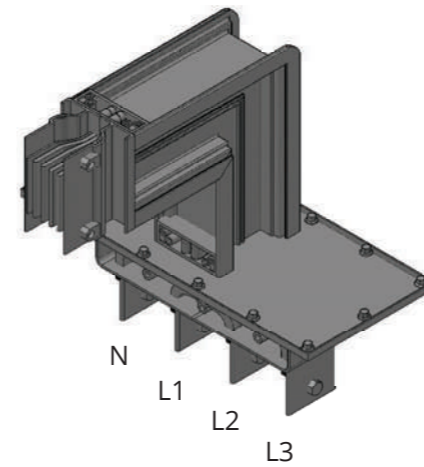

Horizontal Panel Module Right Panel Inlet PM5

**SAMPLE ORDER**  
2500 A Copper Panel Module IP 55 4 Conductor  
**HP-KA275T2FPM5**

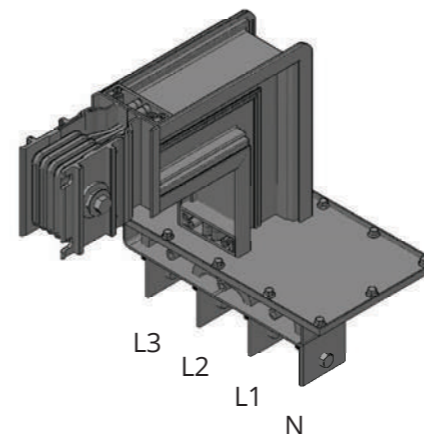

Horizontal Panel Module Left Panel Inlet PM6

**SAMPLE ORDER**  
1600 A Copper Panel Module IP 55 4 Conductor  
**HP-KC175T2FPM6**

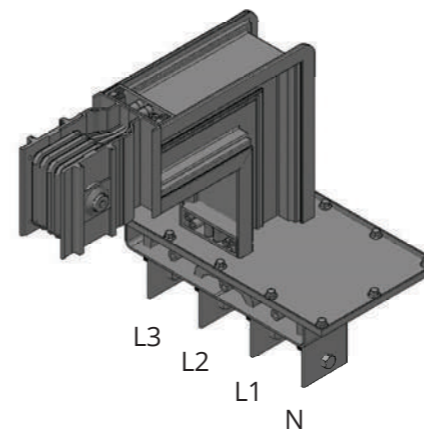

Horizontal Panel Module Right Panel Outlet PM7

**SAMPLE ORDER**  
800 A Copper Panel Module IP 55 4 Conductor  
**HP-KC075T2FPM7**

UPWARDS PANEL MODULE					
It is used for connecting straight lengths to the panel.					
(AL)			(CU)		
AMR.	X mm	T mm	AMR.	X mm	T mm
400A	248	248	550A	248	248
500A	248	248	650A	248	248
630A	248	248	800A	248	248
800A	255	255	1000A	255	255
1000A	268	268	1250A	263	263
1250A	283	283	1350A	268	268
1350A	290	290	1600A	283	283
1600A	308	308	2000A	298	298
2000A	328	328	2250A	308	308
2500A	353	353	2500A	328	328
2500A	342	342	2000A	302	302
3000A	387	387	2500A	328	328
3200A	407	407	3300A	357	357
4000A	447	447	3600A	372	372
5000A	565	565	4000A	387	387
			4250A	407	407
			5000A	447	447
			6300A	565	565

▶ Please contact us for custom-length modules.

### Panel Modules

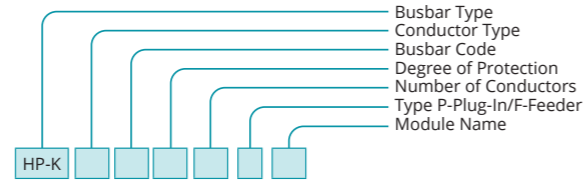
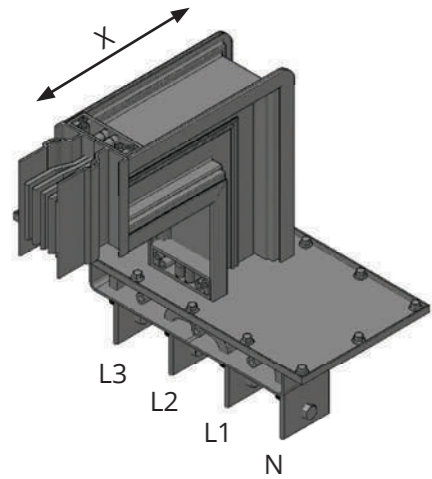

Horizontal Panel Module Left Panel Outlet **PM8**

**SAMPLE ORDER**  
2000 A Aluminum Panel Module IP 55 4 Conductor  
**HP-KA205T2FPM8**

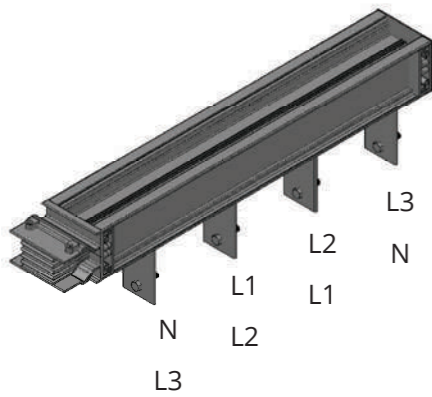

Horizontal Panel Module Inlet **YP1**

**SAMPLE ORDER**  
3300 A Copper Panel Module IP 55 4 Conductor  
**HP-KC335T2FYP1**

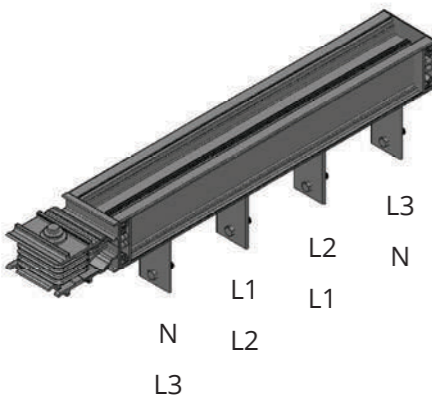
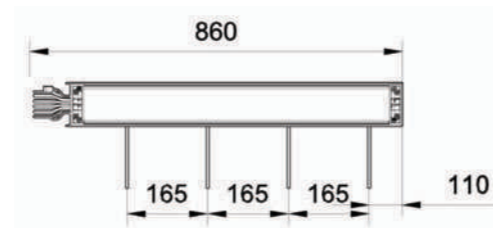

Horizontal Panel Module Outlet **YP2**

**SAMPLE ORDER**  
4000 A Copper Panel Module IP 55 4 Conductor  
**HP-KC415T2FYP2**

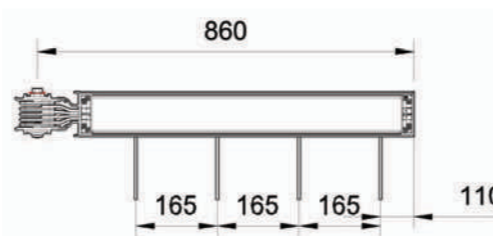

▶ Please contact us for custom-length modules.

### Tee Modules

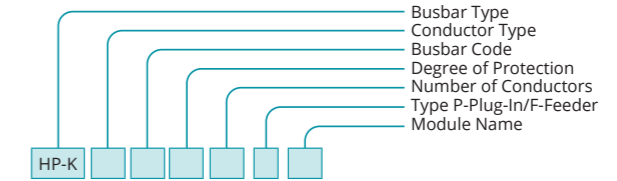
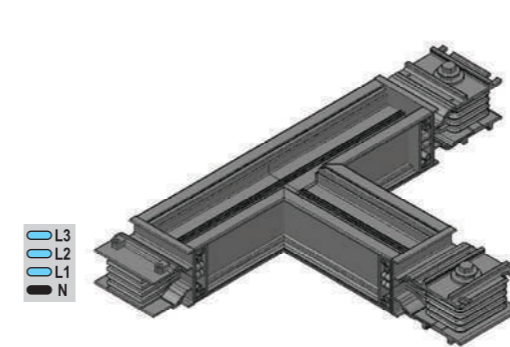

Right Tee Module **RT**

**SAMPLE ORDER**  
1350 A Copper Tee Module IP 55 4 Conductor  
**HP-KC155T2FRT**

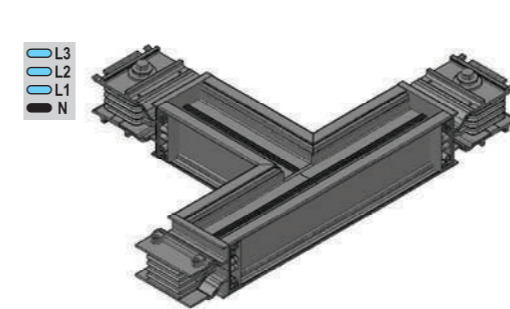

Left Tee Module **LT**

**SAMPLE ORDER**  
1000 A Aluminum Tee Module IP 55 4 Conductor  
**HP-KA105T2FLT**

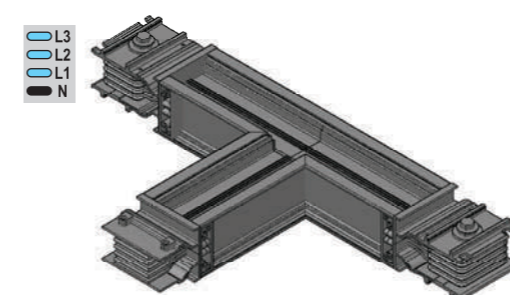

Centre Tee Module **OT**

**SAMPLE ORDER**  
1250 A Aluminum Tee Module IP 55 4 Conductor  
**HP-KA125T2FOT**

HORIZONTAL TEE RIGHT/LEFT							
It is used for taking the line of busbar runs which is horizontally right or left (Tee).							
	(AL)			(CU)			
AMR.	X mm	Y mm	Z mm	AMR.	X mm	Y mm	Z mm
400A	225	225	225	550A	225	225	225
500A	225	225	225	650A	225	225	225
630A	225	225	225	800A	225	225	225
800A	232	232	232	1000A	232	232	232
1000A	244	244	244	1250A	239	239	239
1250A	259	259	259	1350A	244	244	244
1350A	267	267	267	1600A	259	259	259
1600A	284	284	284	2000A	274	274	274
2000A	304	304	304	2250A	284	284	284
2500A	329	329	329	2500A	304	304	304
2500A	334	334	334	2000A	279	279	279
3000A	364	364	364	2500A	304	304	304
3200A	384	384	384	3300A	334	334	334
4000A	424	424	424	3600A	349	349	349
5000A	544	544	544	4000A	364	364	364
				4250A	384	384	384
				5000A	424	424	424
				6300A	544	544	544

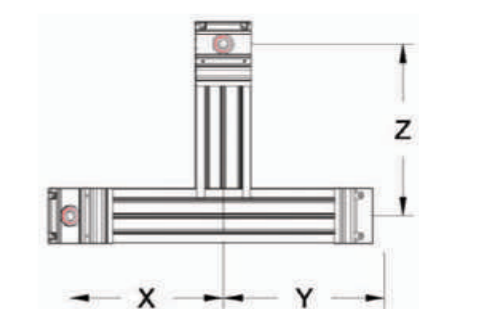

▶ Please contact us for custom-length modules.

### Standard Modules

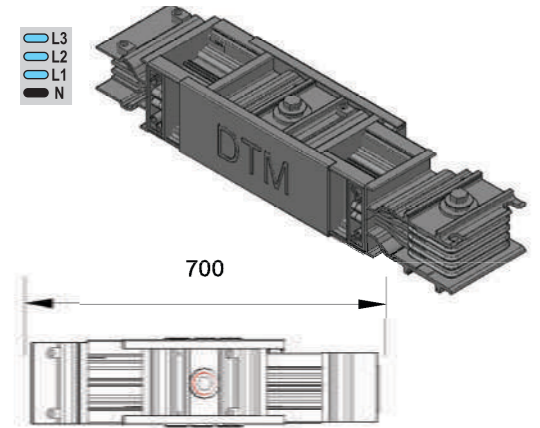

Reduction Module 700 mm **RD**

**SAMPLE ORDER**  
800 A Aluminum Reduction IP 55 4 Conductor  
**HP-KA085T2FRD**

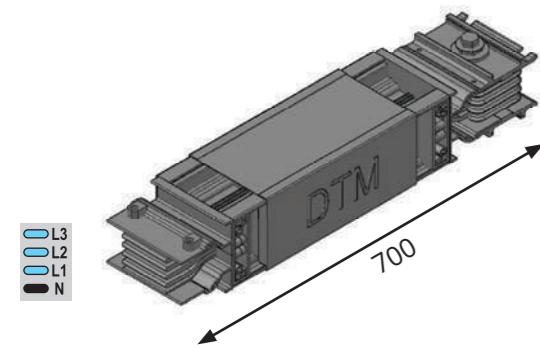

Expansion Module 700 mm **G**

**SAMPLE ORDER**  
800 A Aluminum, Expansion IP 55 4 Conductor  
**HP-KA085T2FG**

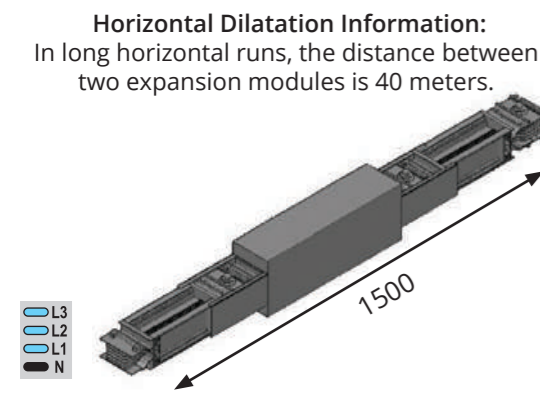

**Horizontal Dilatation Information:**  
In long horizontal runs, the distance between two expansion modules is 40 meters.

Horizontal Dilatation Module 1500 mm **YD**

**SAMPLE ORDER**  
1600 A Aluminum, Dilatation IP 55 4 Conductor  
**HP-KA165T2FYD**



Phase Transposition Module 1500 mm **CM**

**SAMPLE ORDER**  
1000 A Aluminum, Phase Transposition IP 55 4 Conductor  
**HP-KA105T2FCM**

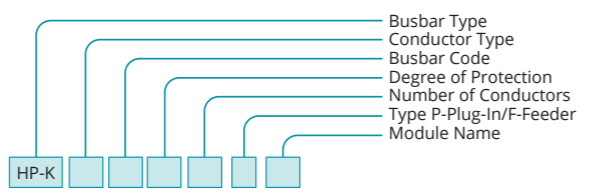

**Reduction Module Reduction Table**

**HP-K WITH AL CONDUCTORS**

Rated Current	Reduced Current Busbar Code															
	04	05	06	08	10	12	14	16	20	25	26	30	32	40		
500	✓	-	-	-	-	-	-	-	-	-	-	-	-	-		
630	✓	✓	-	-	-	-	-	-	-	-	-	-	-	-		
800	-	✓	✓	-	-	-	-	-	-	-	-	-	-	-		
1000	-	-	✓	-	-	-	-	-	-	-	-	-	-	-		
1250	-	-	-	✓	✓	-	-	-	-	-	-	-	-	-		
1350	-	-	-	-	✓	✓	-	-	-	-	-	-	-	-		
1600	-	-	-	-	-	✓	✓	-	-	-	-	-	-	-		
2000	-	-	-	-	-	-	✓	✓	-	-	-	-	-	-		
2500	-	-	-	-	-	-	-	✓	✓	-	-	-	-	-		
2500	-	-	-	-	-	-	-	-	✓	✓	-	-	-	-		
3000	-	-	-	-	-	-	-	-	✓	✓	✓	-	-	-		
3200	-	-	-	-	-	-	-	-	✓	✓	✓	✓	-	-		
4000	-	-	-	-	-	-	-	-	-	✓	✓	✓	✓	-		
5000	-	-	-	-	-	-	-	-	-	-	✓	✓	✓	✓		

**Reduction Module Reduction Table**

**HP-K WITH CU CONDUCTORS**

Rated Current	Reduced Current Busbar Code																
	05	06	07	09	13	15	17	21	23	24	22	27	33	36	41	42	51
650	✓	-	-	-	-	-	-	-	-	-	-	-	-	-	-	-	-
800	✓	✓	-	-	-	-	-	-	-	-	-	-	-	-	-	-	-
1000	-	✓	✓	-	-	-	-	-	-	-	-	-	-	-	-	-	-
1250	-	-	✓	✓	-	-	-	-	-	-	-	-	-	-	-	-	-
1350	-	-	-	✓	✓	-	-	-	-	-	-	-	-	-	-	-	-
1600	-	-	-	-	✓	✓	-	-	-	-	-	-	-	-	-	-	-
2000	-	-	-	-	-	✓	✓	-	-	-	-	-	-	-	-	-	-
2000	-	-	-	-	-	-	✓	✓	-	-	-	-	-	-	-	-	-
2250	-	-	-	-	-	-	-	✓	✓	-	-	-	-	-	-	-	-
2500	-	-	-	-	-	-	-	-	✓	✓	✓	-	-	-	-	-	-
2500	-	-	-	-	-	-	-	-	-	✓	✓	✓	-	-	-	-	-
3300	-	-	-	-	-	-	-	-	-	-	✓	✓	-	-	-	-	-
3600	-	-	-	-	-	-	-	-	-	-	-	✓	✓	-	-	-	-
4000	-	-	-	-	-	-	-	-	-	-	-	-	✓	✓	-	-	-
4250	-	-	-	-	-	-	-	-	-	-	-	-	-	✓	✓	-	-
5000	-	-	-	-	-	-	-	-	-	-	-	-	-	-	✓	✓	-
6300	-	-	-	-	-	-	-	-	-	-	-	-	-	-	-	✓	✓

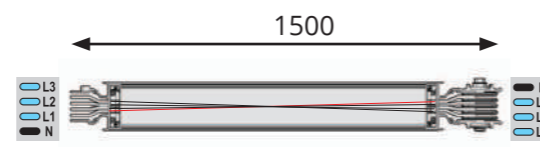

▶ Please contact us for custom-length modules.

### Transformer Modules

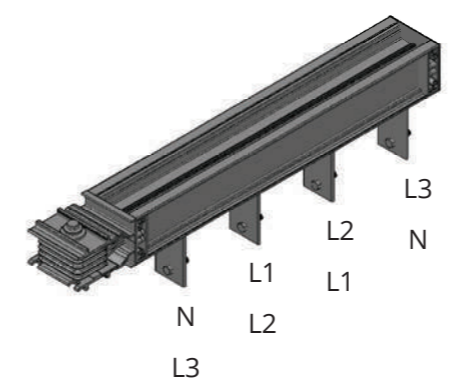

Horizontal Transformer Module **TMH**

**SAMPLE ORDER**  
4000 A Aluminum, Transformer Module IP 55 4 Conductor  
**HP-KA405T2FTMH**



Horizontal Transformer Module **TMF**

**SAMPLE ORDER**  
2000 A Aluminum, Transformer Module IP 55 4 Conductor  
**HP-KA205T2FTMF**

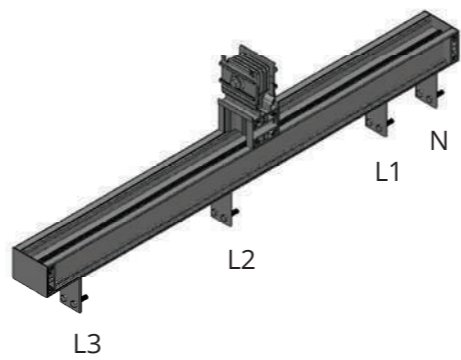

Centre Transformer Module **TMO**

**SAMPLE ORDER**  
1600 A Aluminum, Transformer Module IP 55 4 Conductor  
**HP-KA165T2FTMO**

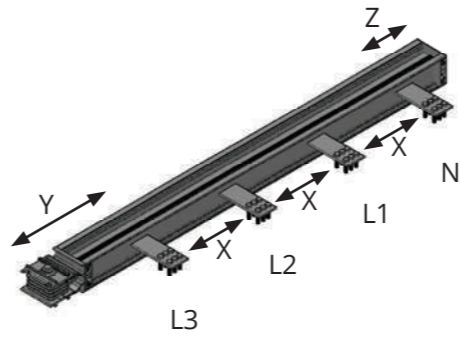

Vertical Transformer Module **TMK**

**SAMPLE ORDER**  
1000 A Aluminum, Transformer Module IP 55 4 Conductor  
**HP-KA105T2FTMK**

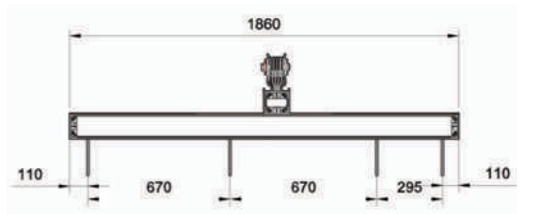
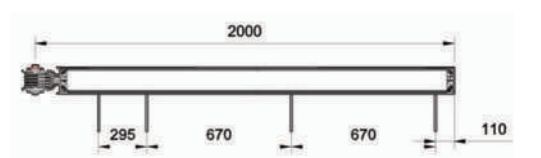
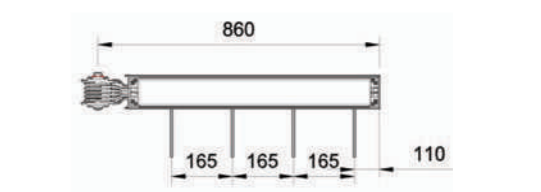
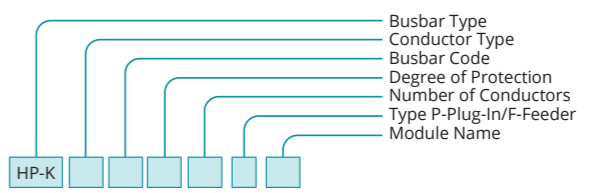

**VERTICAL TRANSFORMER MODULE**

AMR.	(AL)			(CU)			
	X mm	Y mm	Z mm	AMR.	X mm	Y mm	Z mm
400A	100	275	135	550A	100	275	135
500A	100	275	135	650A	100	275	135
630A	100	275	135	800A	100	275	135
800A	115	280	140	1000A	115	280	140
1000A	140	295	155	1250A	130	290	150
1250A	170	305	170	1350A	140	295	150
1350A	185	315	175	1600A	170	310	170
1600A	220	335	195	2000A	200	325	185
2000A	260	355	215	2250A	220	335	195
2500A	310	380	240	2500A	260	355	215
2500A	170	310	170	2000A	115	280	140
3000A	200	325	185	2500A	140	295	155
3200A	220	335	195	3300A	170	310	170
4000A	260	355	215	3600A	185	315	180
5000A	260	355	215	4000A	200	325	185
				4250A	220	335	195
				5000A	260	355	215
				6300A	260	355	215

▶ Please contact us for custom-length modules.

### Transformer Modules

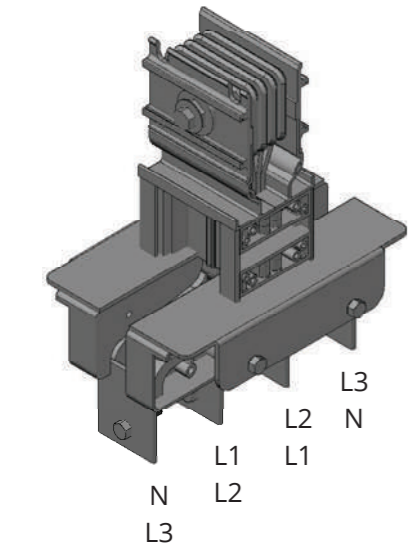
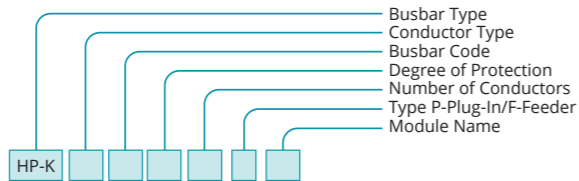

Vertical Transformer Module TR1

**SAMPLE ORDER**  
1000 A Aluminum, Transformer Module IP 55 4 Conductor  
**HP-KA105T2FTR1**

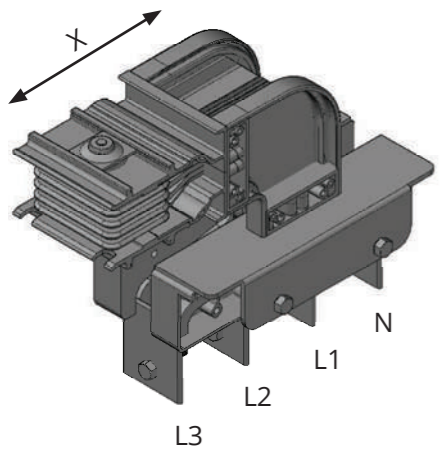

Upwards Transformer Module TRU

**SAMPLE ORDER**  
2500 A Aluminum, Transformer Module IP 55 4 Conductor  
**HP-KA265T2FTRU**

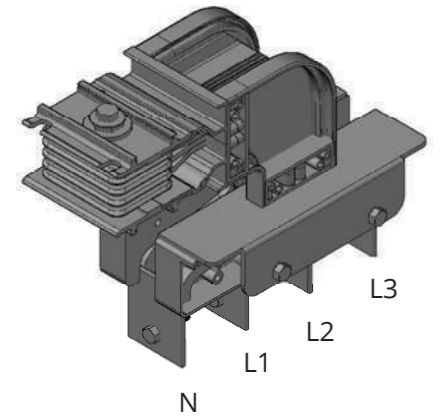

Downwards Transformer Module TRD

**SAMPLE ORDER**  
2000 A Aluminum, Transformer Module IP 55 4 Conductor  
**HP-KA205T2FTRD**

#### VERTICAL TRANSFORMER MODULE

It is used for connecting straight lengths to the panel.

(AL)		(CU)	
AMR.	X mm	AMR.	X mm
400A	220	550A	220
500A	220	650A	220
630A	220	800A	220
800A	220	1000A	220
1000A	220	1250A	220
1250A	220	1350A	220
1350A	220	1600A	220
1600A	220	2000A	220
2000A	220	2250A	220
2500A	220	2500A	220
2500A	220	2000A	220
3000A	220	2500A	220
3200A	220	3300A	220
4000A	220	3600A	220
5000A	220	4000A	220
		4250A	220
		5000A	220
		6300A	220

#### UPWARDS/DOWNWARDS TRANSFORMER MODULE

It is used for connecting straight lengths to the transformer.

(AL)		(CU)			
AMR.	X mm	Y mm	AMR.	X mm	Y mm
400A	230	230	550A	230	230
500A	230	230	650A	230	230
630A	230	230	800A	230	230
800A	230	230	1000A	230	230
1000A	230	230	1250A	230	230
1250A	230	230	1350A	230	230
1350A	230	230	1600A	230	230
1600A	230	230	2000A	230	230
2000A	230	230	2250A	230	230
2500A	230	230	2500A	230	230
2500A	230	230	2000A	230	230
3000A	230	230	2500A	230	230
3200A	230	230	3300A	230	230
4000A	230	230	3600A	230	230
5000A	230	230	4000A	230	230
			4250A	230	230
			5000A	230	230
			6300A	230	230

### Transformer Modules

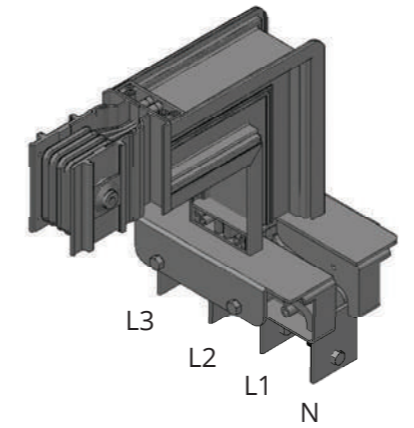
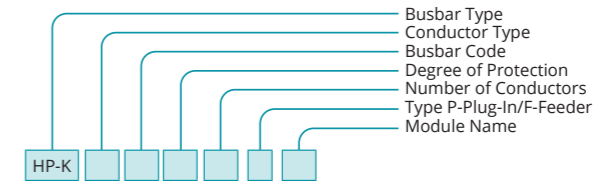

Right Transformer Module TRR

**SAMPLE ORDER**  
3300 A Copper Transformer Module IP 55 4 Conductor  
**HP-KC335T2FTRR**

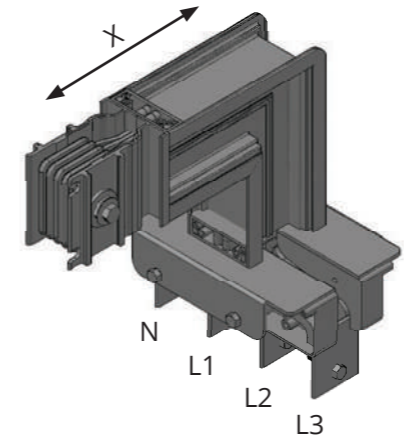

Left Transformer Module TRL

**SAMPLE ORDER**  
1350 A Aluminum, Transformer Module IP 55 4 Conductor  
**HP-KA145T2FTRL**

#### RIGHT/LEFT TRANSFORMER MODULE

It is used for connecting straight lengths to the transformer.

(AL)			(CU)		
AMR.	X mm	Y mm	AMR.	X mm	Y mm
400A	230	230	550A	230	230
500A	230	230	650A	230	230
630A	230	230	800A	230	230
800A	230	230	1000A	230	230
1000A	230	230	1250A	230	230
1250A	230	230	1350A	230	230
1350A	230	230	1600A	230	230
1600A	230	230	2000A	230	230
2000A	230	230	2250A	230	230
2500A	230	230	2500A	230	230
2500A	230	230	2000A	230	230
3000A	230	230	2500A	230	230
3200A	230	230	3300A	230	230
4000A	230	230	3600A	230	230
5000A	230	230	4000A	230	230
			4250A	230	230
			5000A	230	230
			6300A	230	230

Flanged End S1

**SAMPLE ORDER**  
800 A Aluminum, Flanged End IP 55 4 Conductor  
**HP-KA085T2FS1**

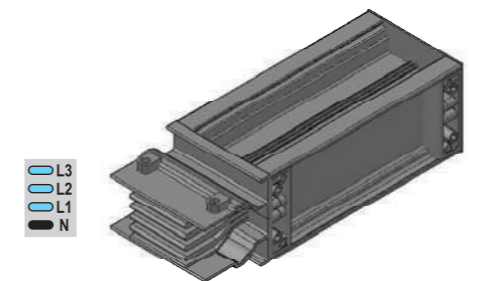

Flanged End S2

**SAMPLE ORDER**  
1000 A Aluminum, Flanged End IP 55 4 Conductor  
**HP-KA105T2FS2**

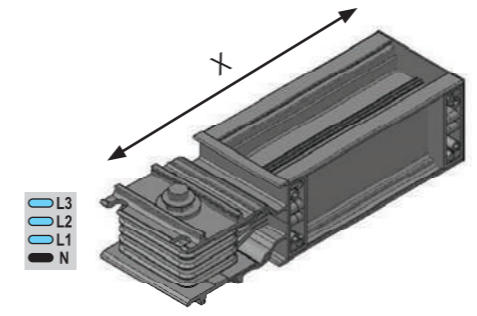

#### FLANGED END

It is used for terminating the line ends.

(AL)		(CU)	
AMR.	X mm	AMR.	X mm
400A	150	550A	150
500A	150	650A	150
630A	150	800A	150
800A	150	1000A	150
1000A	150	1250A	150
1250A	150	1350A	150
1350A	150	1600A	150
1600A	150	2000A	150
2000A	150	2250A	150
2500A	150	2500A	150
2500A	150	2000A	150
3000A	150	2500A	150
3200A	150	3300A	150
4000A	150	3600A	150
5000A	150	4000A	150
		4250A	150
		5000A	150
		6300A	150

▶ Please contact us for custom-length modules.

▶ Please contact us for custom-length modules.

### Feeder Box

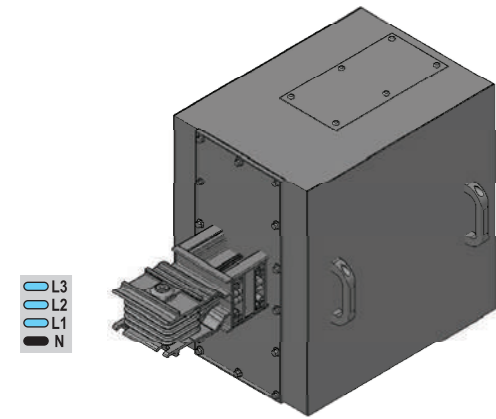

L3  
L2  
L1  
N

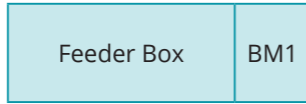
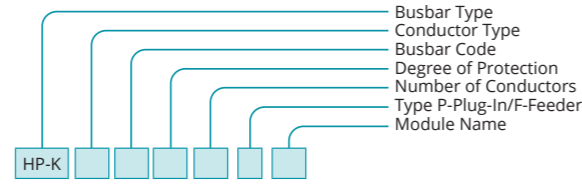

#### SAMPLE ORDER

1350 A Aluminum, Feeder Module IP 55 4 Conductor

**HP-KA145T2R1BM1**

Cable Gland Type



#### CABLE GLAND PLATES

(AL)		(CU)	
AMR.	Cable Gland Type	AMR.	Rekor Tipi
400A	R1	550A	R1
500A	R1	650A	R1
630A	R1	800A	R1
800A	R1	1000A	R1
1000A	R1	1250A	R1
1250A	R1	1350A	R1
1350A	R2	1600A	R1
1600A	R2	2000A	R2
2000A	R2	2250A	R2
2500A	R3	2500A	R2
2500A	R3	2000A	R2
3000A	R3	2500A	R2
3200A	R3	3300A	R3
4000A	R3	3600A	R3
5000A	R5	4000A	R3
		4250A	R3
		5000A	R3
		6300A	R4

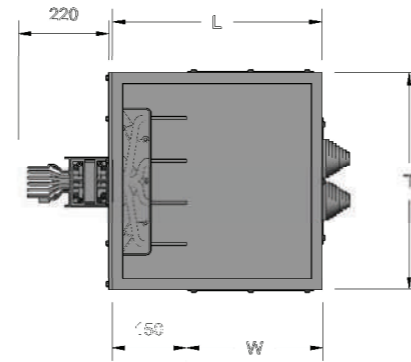
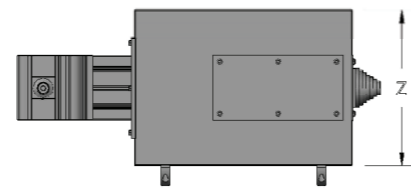

#### UPWARDS/DOWNWARDS TRANSFORMER MODULE

(AL)		(CU)	
AMR.	L mm	T mm	Z mm
400A	520	560	360
500A	520	560	360
630A	520	560	360
800A	520	560	360
1000A	520	560	360
1250A	520	560	360
1350A	520	560	360
1600A	520	560	360
2000A	520	560	360
2500A	520	560	360
2500A	520	560	360
3000A	720	560	370
3200A	720	560	370
4000A	720	560	370
5000A	720	560	370
		4250A	720
		5000A	720
		6300A	720

### Feeder Box

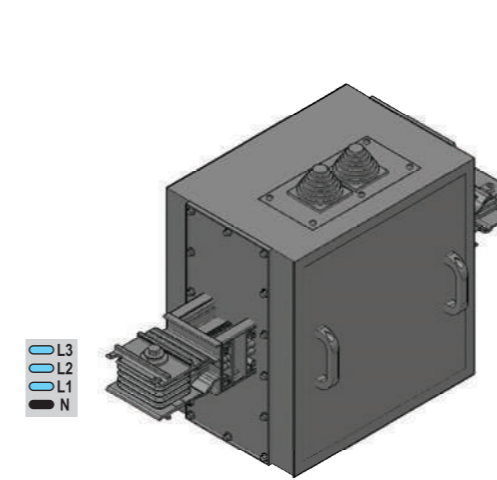

L3  
L2  
L1  
N

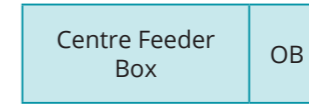
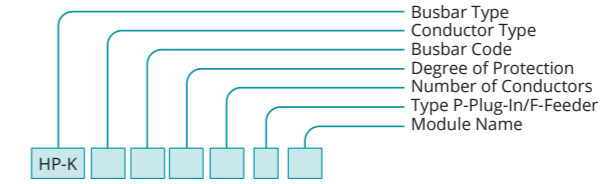

#### SAMPLE ORDER

800 A Aluminum, Feeder Module IP 55 4 Conductor

**HP-KA085T2R1OB**

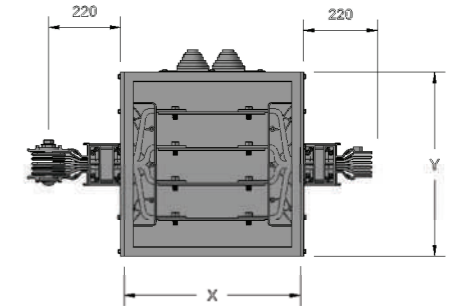
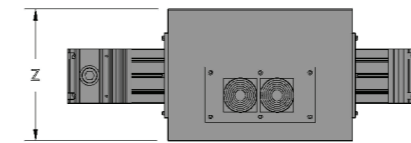

#### CABLE GLAND PLATES

(AL)		(CU)	
AMR.	Cable Gland Type	AMR.	Rekor Tipi
400A	R1	550A	R1
500A	R1	650A	R1
630A	R1	800A	R1
800A	R1	1000A	R1
1000A	R1	1250A	R1
1250A	R1	1350A	R1
1350A	R2	1600A	R1
1600A	R2	2000A	R2
2000A	R2	2250A	R2
2500A	R3	2500A	R2
2500A	R3	2000A	R2
3000A	R3	2500A	R2
3200A	R3	3300A	R3
4000A	R3	3600A	R3
5000A	R5	4000A	R3
		4250A	R3
		5000A	R3
		6300A	R4

#### CENTRE FEEDER

(AL)		(CU)	
AMR.	L mm	T mm	Z mm
400A	520	560	360
500A	520	560	360
630A	520	560	360
800A	520	560	360
1000A	520	560	360
1250A	520	560	360
1350A	520	560	360
1600A	720	560	360
2000A	720	560	360
2500A	720	560	360
2500A	720	560	360
3000A	870	560	360
3200A	870	560	360
4000A	870	560	360
5000A	870	560	360
		4250A	870
		5000A	870
		6300A	870

► Please contact us for custom-length modules.

► Please contact us for custom-length modules.

### ▶ Tap-Off Unit, With Compact Switch (Bolt-On)

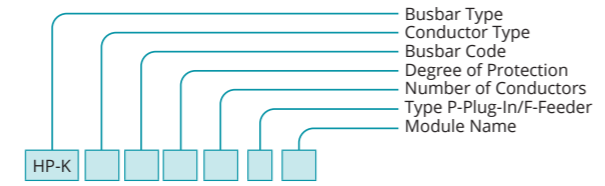
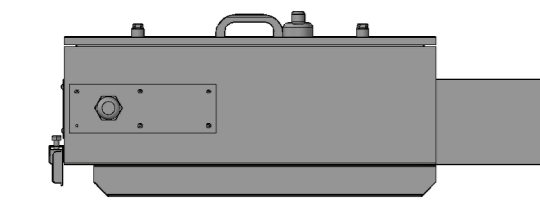
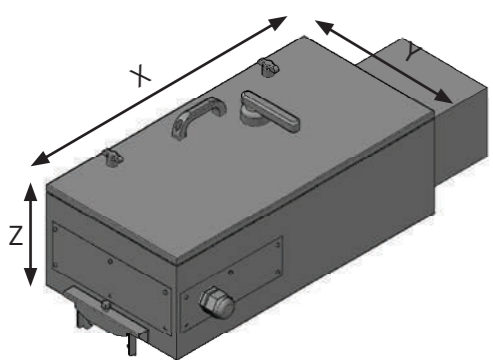

With Compact Switch (Bolt-On)	HPB
-------------------------------	-----

**SAMPLE ORDER**  
250 A Tap-Off Unit  
Empty IP 55 4 Conductor  
**HPB255T2R3B**

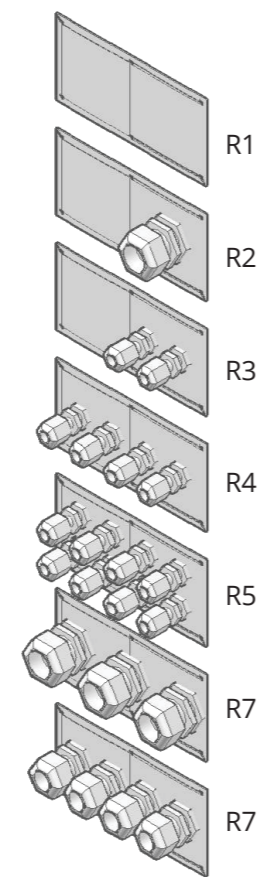

SWITCH TYPE CODE	
With Switch	Empty
S	B

CABLE GLAND PLATES	
Cable Gland Type	Code No
-	R1
RG36X1	R2
RG29X2	R3
RG21X4	R4
RG29X8	R5
RG48X3	R6
RG36X4	R7

**Note:**

DTM's bolt-on tap-off unit must be installed in the place of installation in addition to the joint block in accordance with the technical diagram.

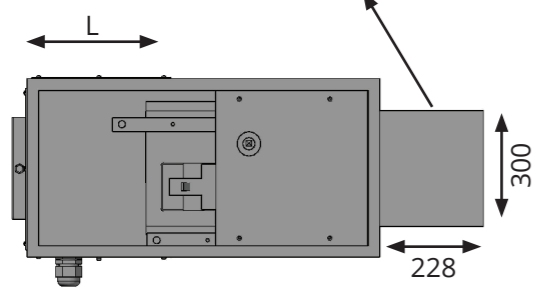

Amp.	Unit Code	T mm	Z mm	W mm	L mm
250	HPB25	450	385	260	150
400	HPB40	560	385	260	200
630	HPB63	560	385	260	200
800	HPB80	700	425	260	250
1000	HPB10	700	425	260	250

▶ Please contact us for custom-length modules.

### ▶ Tap-Off Unit, With DTM Mechanism (Bolt-On)

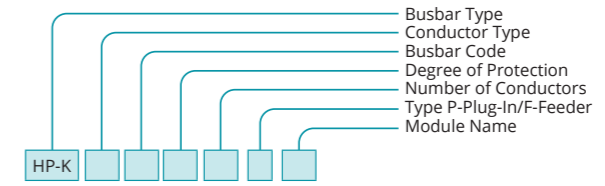
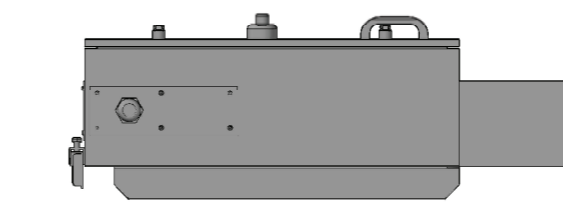
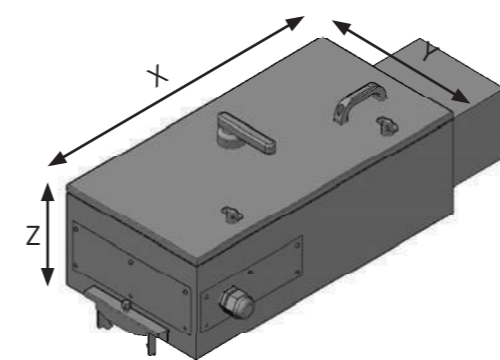

With Mechanism (Bolt-On)	HPM
--------------------------	-----

**SAMPLE ORDER**  
400 A Tap-Off Unit  
Empty IP 55 4 Conductor  
**HPM405T2R4B**

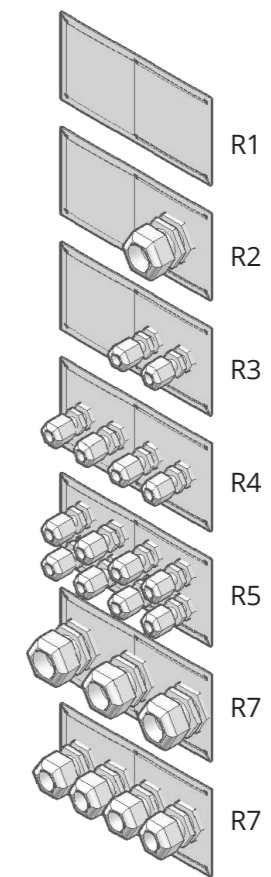

SWITCH TYPE CODE	
With Switch	Empty
S	B

CABLE GLAND PLATES	
Cable Gland Type	Code No
-	R1
RG36X1	R2
RG29X2	R3
RG21X4	R4
RG29X8	R5
RG48X3	R6
RG36X4	R7

**Note:**

DTM's bolt-on tap-off unit must be installed in the place of installation in addition to the joint block in accordance with the technical diagram.

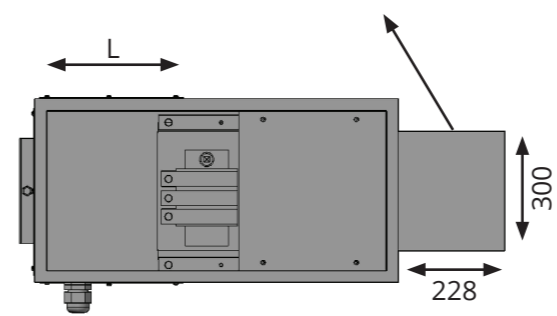

Amp.	Unit Code	T mm	Z mm	W mm	L mm
160	HPMB16	500	385	260	150
250	HPMB25	500	385	260	150
400	HPMB40	760	425	260	200
630	HPMB63	760	425	260	200

**Note:**

DTM's bolt-on tap-off units cannot be mechanically attached to/detached from the busbar when they are "ON".

There is a special mechanism to turn these units off when the units are set to "OFF" and the units are powered by the same mechanism when they are set to "ON".

The units equipped with a standard mechanism are delivered as empty. Before attaching such units to the busbar, a fuse switch disconnecter, a group of switches or a similar protective unit must be placed into them.

▶ Please contact us for custom-length modules.

▶ Tap-Off Unit, With Compact Switch (Plug-In)

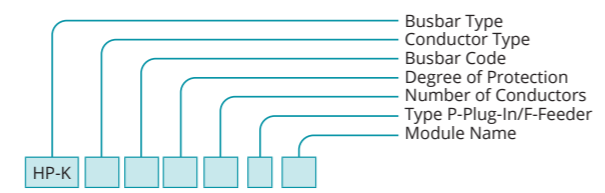
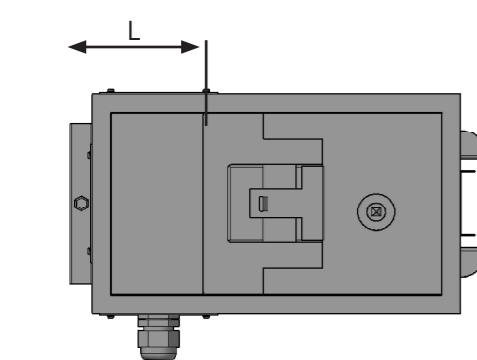
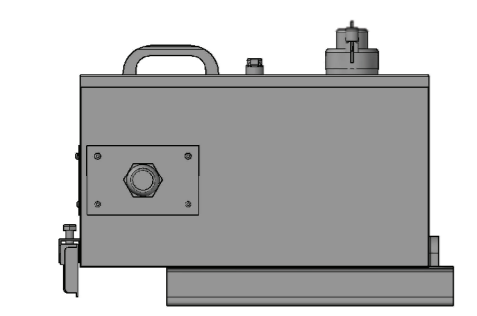
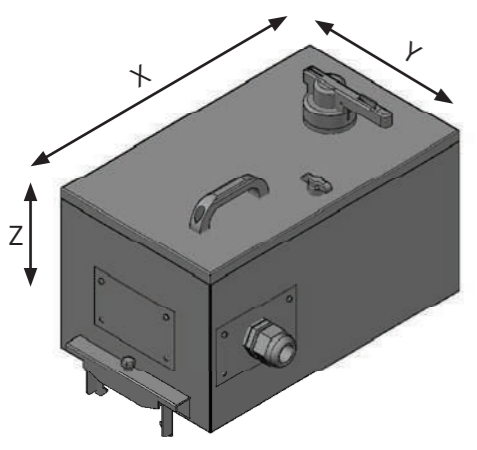

With Compact Switch (Plug-In)	HPS
-------------------------------	-----

**SAMPLE ORDER**  
630 A Tap-Off Unit With Switch  
IP 55 4 Conductor  
**HPS635T2R5S**

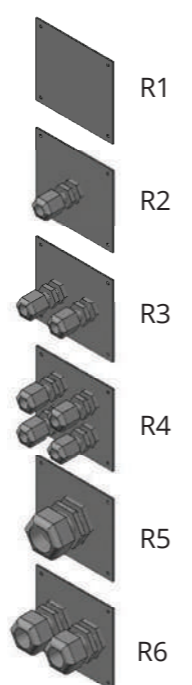

SWITCH TYPE CODE	
With Switch	Empty
S	B

CABLE GLAND PLATES	
Cable Gland Type	Code No
-	R1
RG36X1	R2
RG29X2	R3
RG21X4	R4
RG29X1	R5
RG48X2	R6

Amp.	Unit Code	T mm	Z mm	W mm	L mm
160	HPS16	530	300	220	155
250	HPS25	530	300	220	155
400	HPS40	710	300	220	260
630	HPS63	710	300	220	260

▶ Please contact us for custom-length modules.

▶ Tap-Off Unit, With DTM Mechanism (Plug-In)

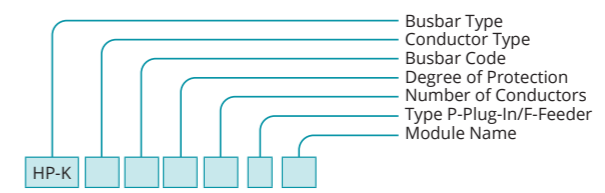
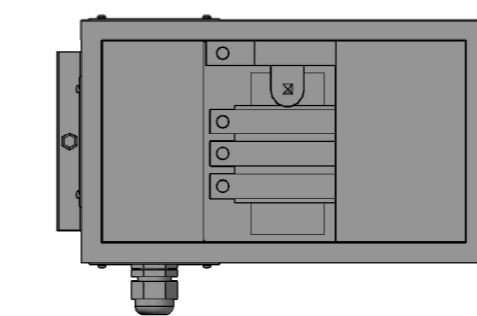
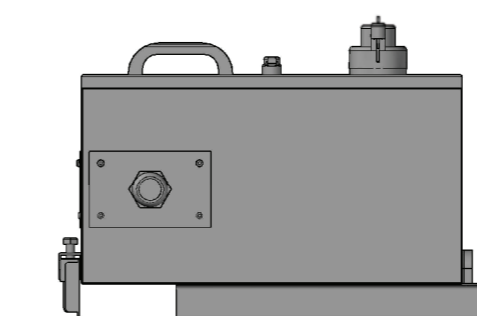
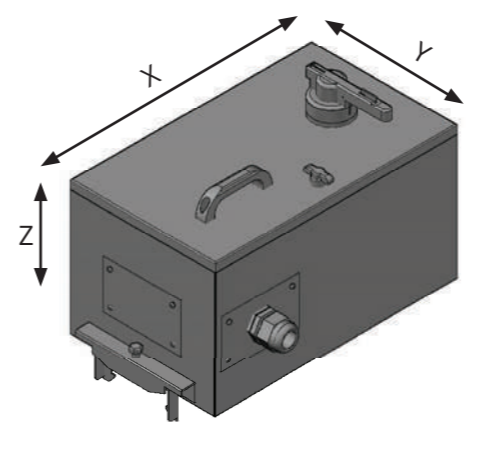

With Mechanism (Plug-In)	HPP
--------------------------	-----

**SAMPLE ORDER**  
160 A Tap-Off Unit  
Empty IP 55 4 Conductor  
**HPP165T2R2B**

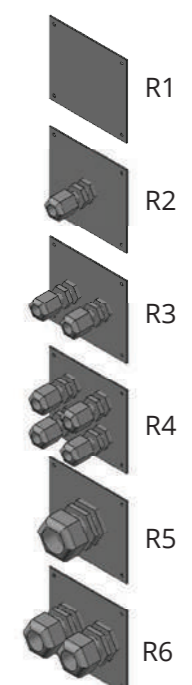

SWITCH TYPE CODE	
With Switch	Empty
S	B

CABLE GLAND PLATES	
Cable Gland Type	Code No
-	R1
RG36X1	R2
RG29X2	R3
RG21X4	R4
RG29X1	R5
RG48X2	R6

Amp.	Unit Code	T mm	Z mm	W mm	L mm
160	HPP16	530	300	220	155
250	HPP25	530	300	220	155
400	HPP40	710	300	220	260
500	HPP50	710	300	220	260

**Note:**  
DTM's bolt-on tap-off units cannot be mechanically attached to/detached from the busbar when they are "ON".  
There is a special mechanism to turn these units off when the units are set to "OFF" and the units are powered by the same mechanism when they are set to "ON".  
The units equipped with a standard mechanism are delivered as empty. Before attaching such units to the busbar, a fuse switch disconnecter, a group of fuses or a similar protective unit must be placed into the units.

▶ Please contact us for custom-length modules.



### Panel Module Dimensions

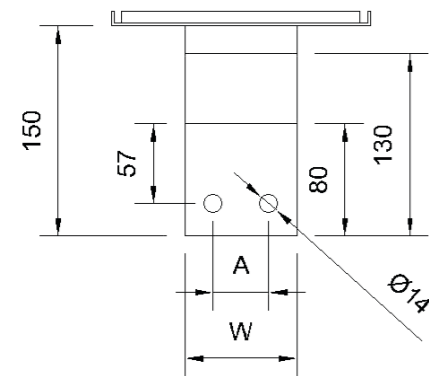
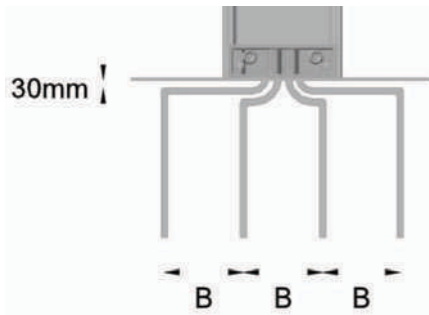
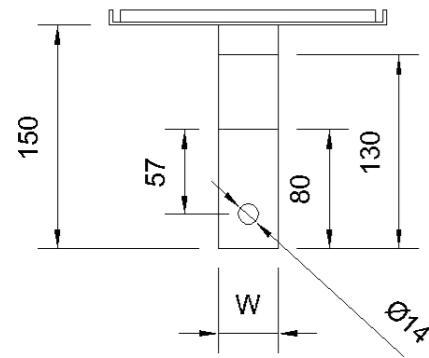
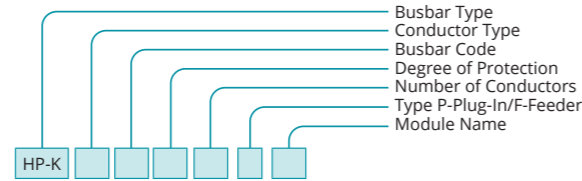

Amp. (AL)	W	Ø 14 mm A	B
400A	25	-	100
500A	30	-	
630A	40	-	
800A	55	-	
1000A	80	40X2	
1250A	110	40X3	120
1350A	125	40X3	
1600A	160	40X4	
2000A	200	40X5	
2500A	(2) 110	40X6	
2500A	(2) 250	40X6	
3000A	(2) 140	40X8	
3200A	(2) 160	40X9	
4000A	(2) 200	40X11	
5000A	(3) 200	40X17	

Amp. (CU)	W	Ø 14 mm A	B
550A	25	-	100
650A	30	-	
800A	40	-	
1000A	55	-	
1250A	70	40X2	
1350A	80	40X2	120
1600A	110	40X3	
2000A	140	40X3	
2250A	160	40X4	
2500A	200	40X5	
2000A	(2) 55	40X3	
2500A	(2) 80	40X5	
3300A	(2) 110	40X6	
3600A	(2) 125	40X7	
4000A	(2) 140	40X8	
4250A	(2) 160	40X9	
5000A	(2) 200	40X11	
6300A	(3) 200	40X17	

▶ Please contact us for custom-length modules.

### Transformer Module Dimensions

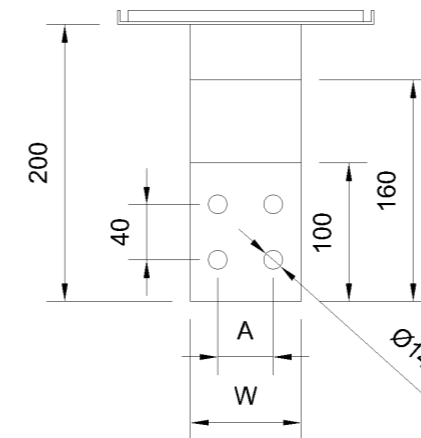
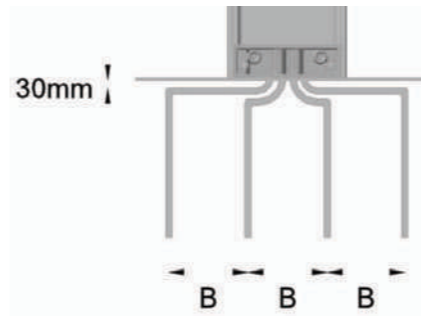
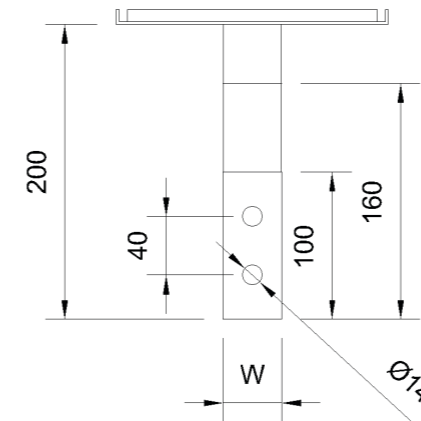
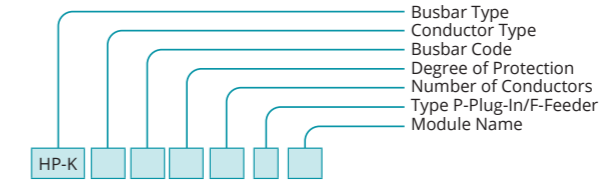

Amp. (AL)	W	Ø 14 mm A	B
400A	25	40X1	100
500A	30	40X1	
630A	40	40X1	
800A	55	40X1	
1000A	80	40X2	
1250A	110	40X3	120
1350A	125	40X3	
1600A	160	40X4	
2000A	200	40X5	
2500A	(2) 110	40X6	
2500A	(2) 250	40X6	
3000A	(2) 140	40X6	
3200A	(2) 160	40X8	
4000A	(2) 200	40X10	
5000A	(3) 200	40X15	

Amp. (CU)	W	Ø 14 mm A	B
550A	25	40X1	100
650A	30	40X1	
800A	40	40X1	
1000A	55	40X1	
1250A	70	40X2	
1350A	80	40X2	120
1600A	110	40X3	
2000A	140	40X3	
2250A	160	40X4	
2500A	200	40X5	
2000A	(2) 55	40X2	
2500A	(2) 80	40X4	
3300A	(2) 110	40X6	
3600A	(2) 125	40X6	
4000A	(2) 140	40X6	
4250A	(2) 160	40X8	
5000A	(2) 200	40X10	
6300A	(3) 200	40X15	

▶ Please contact us for custom-length modules.

Panel Flange Dimensions

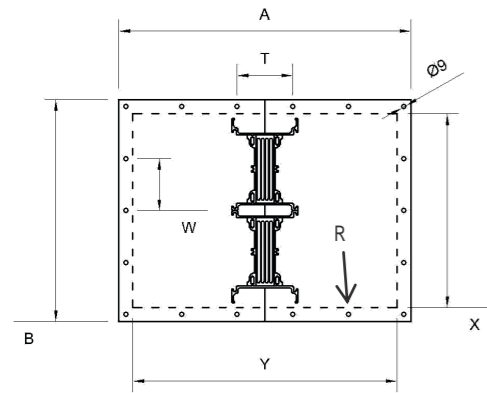
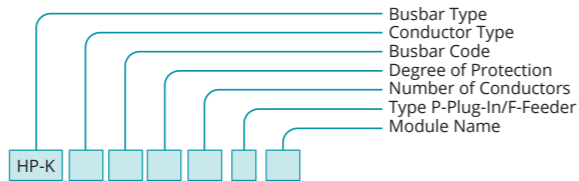

FIG 2

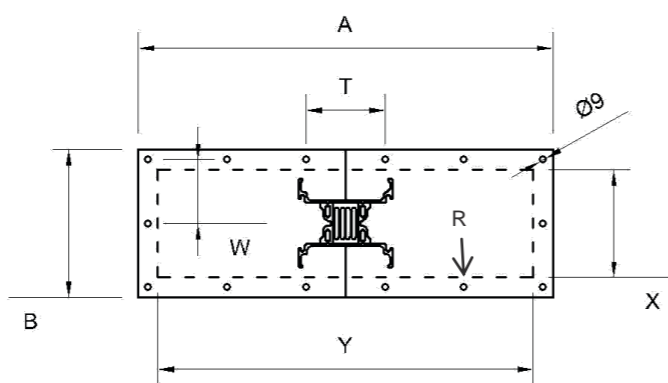

FIG 1

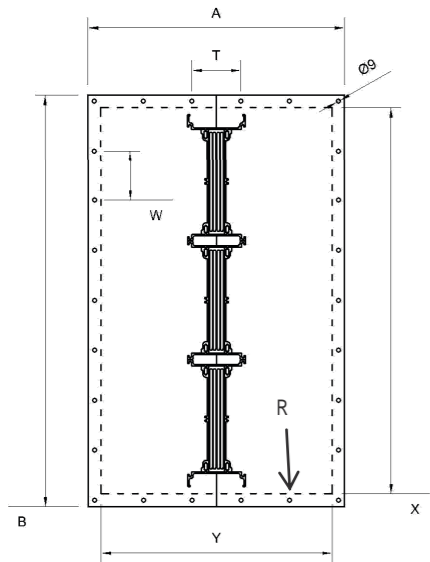

FIG 3

CONNECTION UNIT TOP FLANGE DIMENSIONS (AL)									
AMR.	A (mm)	B (mm)	Y (mm)	X (mm)	T (mm)	R	W (mm)	Ø9 MM R	FIG
400A	520	185	460	125	97	6	75	3	1
500A	520	185	460	125	97	6	75	3	1
630A	520	185	460	125	97	6	75	3	1
800A	520	205	460	145	97	6	85	3	1
1000A	520	230	460	170	97	6	97.5	3	1
1250A	520	260	460	200	97	6	112.5	3	1
1350A	520	275	460	215	97	6	120	3	1
1600A	520	310	460	250	97	6	91.5	4	1
2000A	520	350	460	290	97	6	78.5	5	1
2500A	520	607	460	547	97	6	92.5	5	2
2500A	520	687	460	627	97	6	86	6	2
3000A	520	467	460	407	97	6	94	6	2
3200A	520	507	460	447	97	6	78	6	2
4000A	520	587	460	527	97	6	78.5	8	2
5000A	520	825	460	765	97	6	98.5	9	3

CONNECTION UNIT TOP FLANGE DIMENSIONS (CU)									
AMR.	A (mm)	B (mm)	Y (mm)	X (mm)	T (mm)	R	W (mm)	Ø9 MM R	FIG
550A	520	185	460	125	97	6	75	3	1
650A	520	185	460	125	97	6	75	3	1
800A	520	185	460	125	97	6	75	3	1
1000A	520	205	460	145	97	6	85	3	1
1250A	520	220	460	160	97	6	90	3	1
1350A	520	230	460	170	97	6	97.5	3	1
1600A	520	260	460	200	97	6	112.5	3	1
2000A	520	290	460	230	97	6	83	4	1
2250A	520	310	460	250	97	6	91.5	4	1
2500A	520	350	460	290	97	6	78.5	5	1
2000A	520	297	460	237	97	6	86.5	4	2
2500A	520	347	460	287	97	6	77.5	5	2
3300A	520	407	460	347	97	6	92.5	5	2
3600A	520	437	460	377	97	6	80	6	2
4000A	520	467	460	407	97	6	86	6	2
4250A	520	507	460	447	97	6	94	6	2
5000A	520	587	460	527	97	6	78.5	8	2
6300A	520	825	460	765	97	6	98.5	9	3

Please contact us for custom-length modules.

Flexible Connection

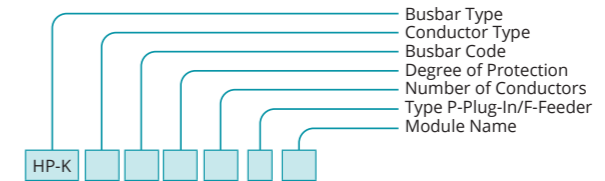

FLEXIBLE

In order to prevent vibration transmission, flexible connections are used if it is necessary to mechanically disjoin the transformer to the connection interface of the busbar.

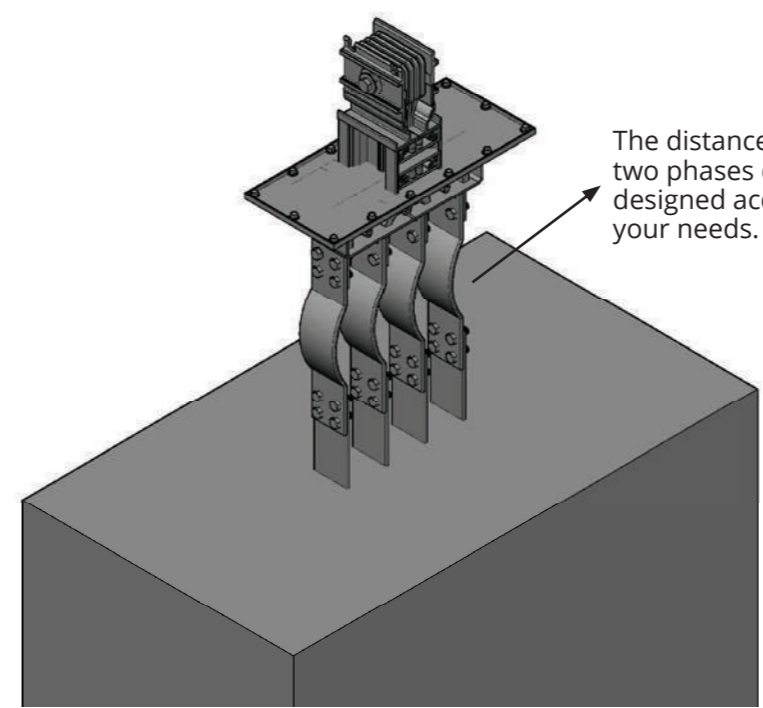

Please contact us for custom-length modules.

Flexible Connection Busbar	FB
----------------------------	----

**SAMPLE ORDER**  
1250 A Aluminum Flexible Busbar  
IP 55 4 Conductor  
**HP-KA125T2FB**

FLEXIBLE BUSBAR CU			
AL		CU	
AMR	W	AMR	W
400A	300-450	550A	300-450
500A	300-450	650A	300-450
630A	300-450	800A	300-450
800A	300-450	1000A	300-450
1000A	300-450	1250A	300-450
1250A	300-450	1350A	300-450
1350A	300-450	1600A	300-450
1600A	300-450	2000A	300-450
2000A	300-450	2250A	300-450
2500A	300-450	2500A	300-450
2500A	300-450	2000A	300-450
3000A	300-450	2500A	300-450
3200A	300-450	3300A	300-450
4000A	300-450	3600A	300-450
5000A	300-450	4000A	300-450
		4250A	300-450
		5000A	300-450
		6300A	300-450

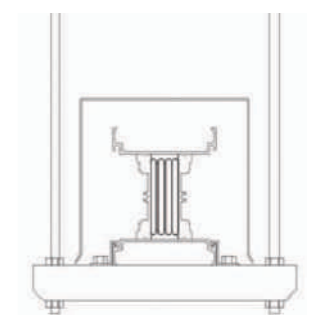

CANOPY

A canopy system must be used in any open space where IP55 is not adequate as the degree of protection. The application of a canopy system does not change the degree of protection of the busbar.

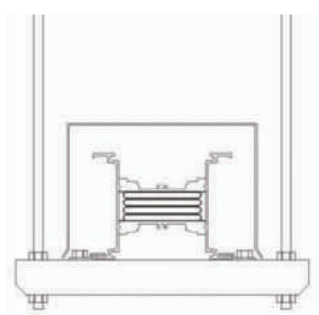

### Panel Bellows Flange

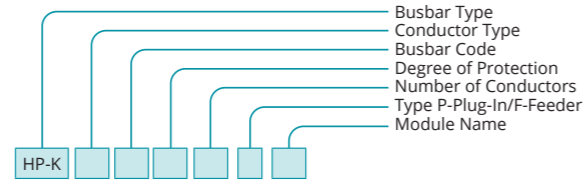
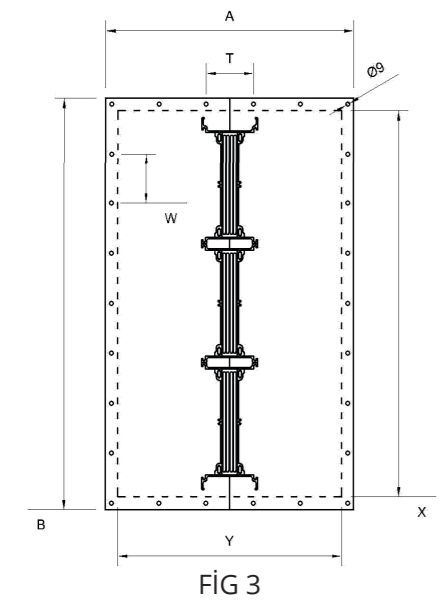
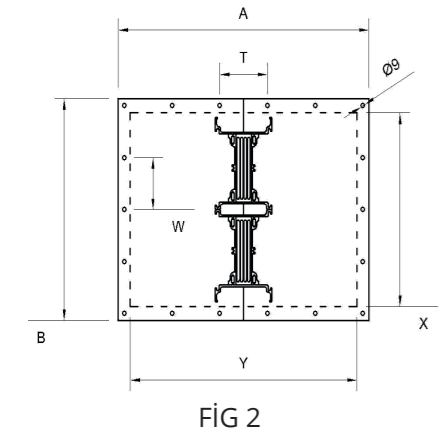
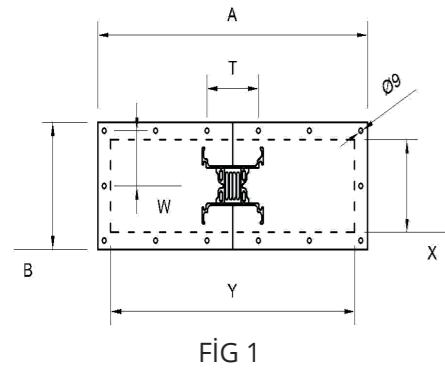

Panel Bellows Flange	PKF
----------------------	-----

**SAMPLE ORDER**  
2500 A Aluminum  
Panel Bellows  
IP 55 4 Conductor  
**HPS635T2R5S**

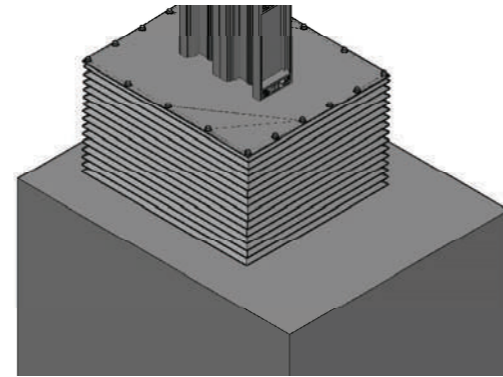

CONNECTION UNIT TOP FLANGE DIMENSIONS (AL)										
AMR.	A (mm)	B (mm)	Y (mm)	X (mm)	T (mm)	R	W (mm)	Ø9 MM R	FIG	
400A	520	185	460	125	97	6	75	3	1	
500A	520	185	460	125	97	6	75	3	1	
630A	520	185	460	125	97	6	75	3	1	
800A	520	205	460	145	97	6	85	3	1	
1000A	520	230	460	170	97	6	97.5	3	1	
1250A	520	260	460	200	97	6	112.5	3	1	
1350A	520	275	460	215	97	6	120	3	1	
1600A	520	310	460	250	97	6	91.5	4	1	
2000A	520	350	460	290	97	6	78.5	5	1	
2500A	520	607	460	547	97	6	92.5	5	2	
2500A	520	687	460	627	97	6	86	6	2	
3000A	520	467	460	407	97	6	94	6	2	
3200A	520	507	460	447	97	6	78	6	2	
4000A	520	587	460	527	97	6	78.5	8	2	
5000A	520	825	460	765	97	6	98.5	9	3	

CONNECTION UNIT TOP FLANGE DIMENSIONS (CU)										
AMR.	A (mm)	B (mm)	Y (mm)	X (mm)	T (mm)	R	W (mm)	Ø9 MM R	FIG	
550A	520	185	460	125	97	6	75	3	1	
650A	520	185	460	125	97	6	75	3	1	
800A	520	185	460	125	97	6	75	3	1	
1000A	520	205	460	145	97	6	85	3	1	
1250A	520	220	460	160	97	6	90	3	1	
1350A	520	230	460	170	97	6	97.5	3	1	
1600A	520	260	460	200	97	6	112.5	3	1	
2000A	520	290	460	230	97	6	83	4	1	
2250A	520	310	460	250	97	6	91.5	4	1	
2500A	520	350	460	290	97	6	78.5	5	1	
2000A	520	297	460	237	97	6	86.5	4	2	
2500A	520	347	460	287	97	6	77.5	5	2	
3300A	520	407	460	347	97	6	92.5	5	2	
3600A	520	437	460	377	97	6	80	6	2	
4000A	520	467	460	407	97	6	86	6	2	
4250A	520	507	460	447	97	6	94	6	2	
5000A	520	587	460	527	97	6	78.5	8	2	
6300A	520	825	460	765	97	6	98.5	9	3	

▶ Please contact us for custom-length modules.

### Horizontal Hanger Kit (U)

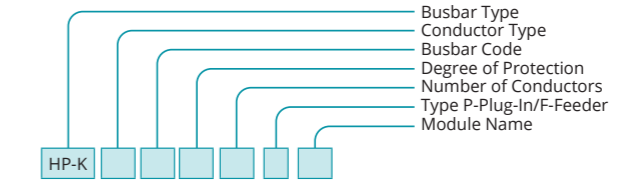
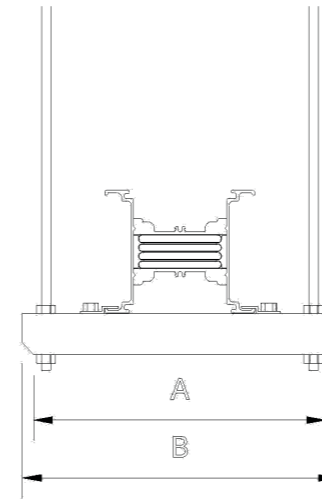

Custom Horizontal Hanger Kit Horizontal Application	YUP
---	-----

**SAMPLE ORDER**  
5000 A Aluminum  
Horizontal Hanger  
IP 55 4 Conductor  
**HP-KA505T2YUP**

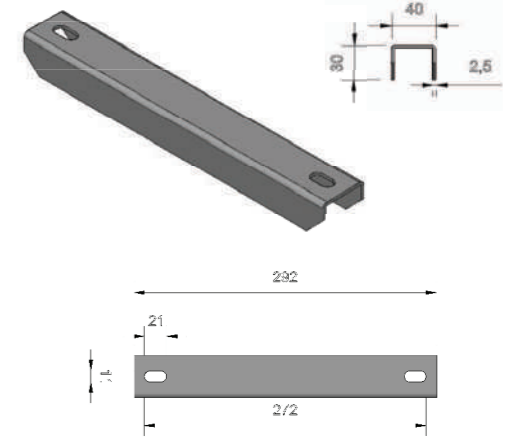

FITTINGS		
Description	W(mm)	Code
B-E 12 Rod Hanger (M10)	500	BE101
B-E 12 Rod Hanger (M10)	1000	BE102
B-E 14 Rod Hanger (M12)	500	BE103
B-E 14 Rod Hanger (M12)	1000	BE104
(M10) Extension Member	-	BE105
(M12) Extension Member	-	BE106
M 10 Draw-In Anchor	-	BE107
M 12 Draw-In Anchor	-	BE108
M 10 Steel Nut	-	BE109
M 12 Steel Nut	-	BE110
M 10 Washer	-	BE111
M 12 Washer	-	BE112

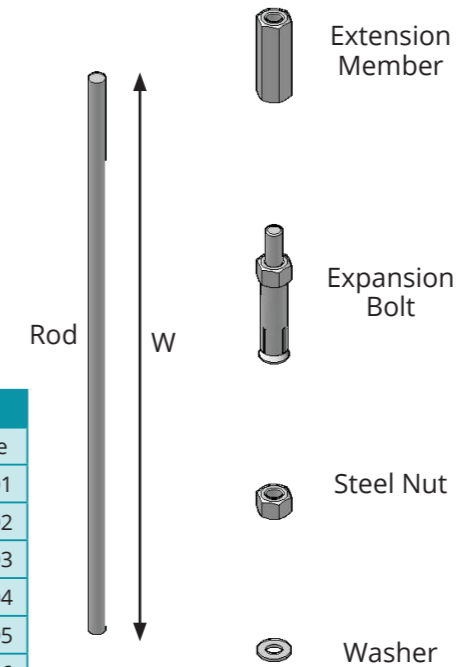

CUSTOM HORIZONTAL HANGER KIT HORIZONTAL APPLICATION					
AMR	(AL)		AMR	(CU)	
	A	B		A	B
400A	252	292	550A	252	292
500A	252	292	650A	252	292
630A	252	292	800A	252	292
800A	267	307	1000A	267	307
1000A	292	332	1250A	282	322
1250A	322	362	1350A	292	332
1350A	337	377	1600A	322	362
1600A	372	412	2000A	352	392
2000A	412	452	2250A	372	412
2500A	669	709	2500A	412	452
2500A	749	789	2000A	359	399
3000A	529	569	2500A	409	449
3200A	569	609	3300A	469	509
4000A	649	689	3600A	499	539
5000A	887	927	4000A	529	569
			4250A	569	609
			5000A	649	689
			6300A	887	927

Drill Bit Diameter:  
M10.....Ø14  
M12.....Ø16

▶ Please contact us for custom-length modules.

### Custom Horizontal Hanger (U)

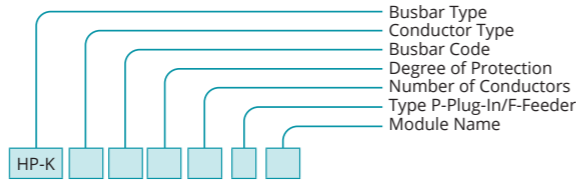

Horizontal Ceiling Kit	YTK
------------------------	-----

**SAMPLE ORDER**  
1000 A Aluminum  
Horizontal Ceiling Kit  
IP 55 4 Conductor  
**HP-KA105T2YTK**

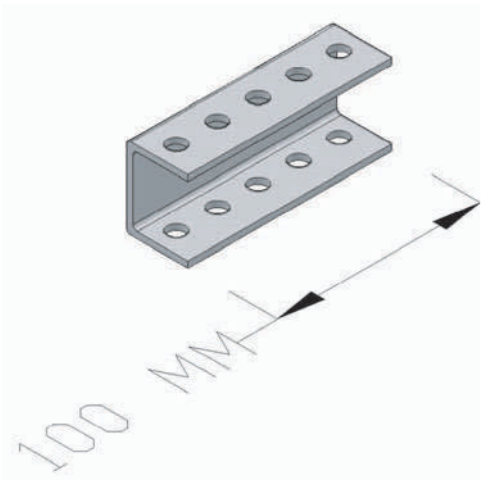

#### HORIZONTAL CEILING CONNECTION KIT (U PROFILE)

AL		CU	
AMR	A	AMR	A
400A	100	550A	100
500A	100	650A	100
630A	100	800A	100
800A	100	1000A	100
1000A	100	1250A	100
1250A	100	1350A	100
1350A	100	1600A	100
1600A	100	2000A	100
2000A	100	2250A	100
2500A	100	2500A	100
2500A	100	2000A	100
3000A	100	2500A	100
3200A	100	3300A	100
4000A	100	3600A	100
5000A	100	4000A	100
		4250A	100
		5000A	100
		6300A	100

Horizontal Hanger Kit Custom	YVA
------------------------------	-----

**SAMPLE ORDER**  
1000 A Aluminum  
Horizontal Hanger  
IP 55 4 Conductor  
**HP-KA105T2YVA**

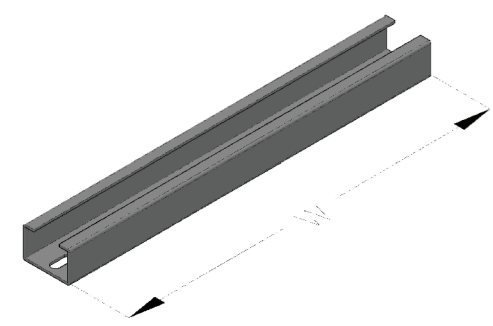

#### HORIZONTAL HANGER KIT VERTICAL CUSTOM (U PROFILE)

AL		CU	
AMR	A	AMR	A
400A	355	550A	355
500A	355	650A	355
630A	355	800A	355
800A	355	1000A	355
1000A	355	1250A	355
1250A	355	1350A	355
1350A	355	1600A	355
1600A	355	2000A	355
2000A	355	2250A	355
2500A	355	2500A	355
2500A	355	2000A	355
3000A	355	2500A	355
3200A	355	3300A	355
4000A	355	3600A	355
5000A	355	4000A	355
		4250A	355
		5000A	355
		6300A	355

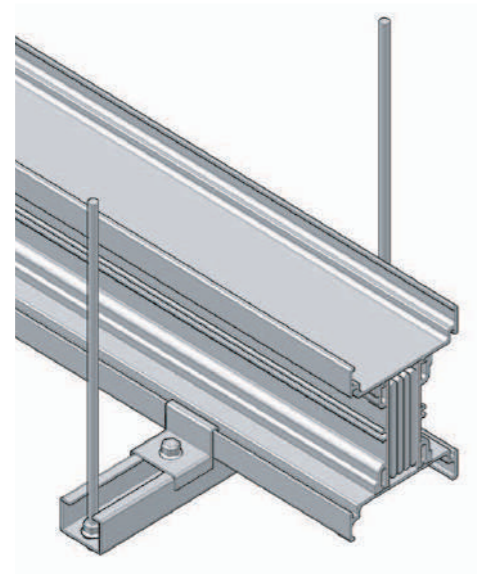

▶ Please contact us for custom-length modules.

### Fixed Shaft Hanger Kit

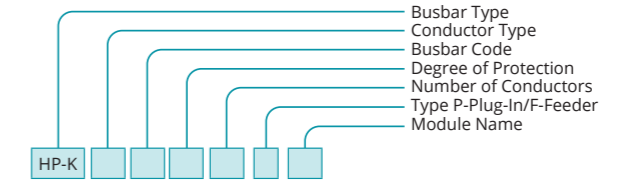

Shaft Hanger Kit	HPS
------------------	-----

**SAMPLE ORDER**  
1250 A Aluminum  
Shaft Hanger  
IP 55 4 Conductor  
**HP-KA125T2HPS**

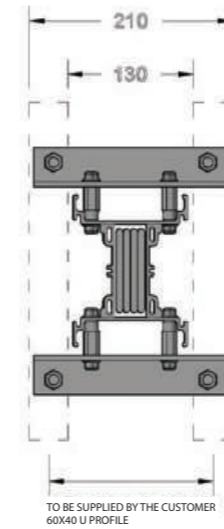

TO BE SUPPLIED BY THE CUSTOMER  
60X40 U PROFILE

TOP VIEW

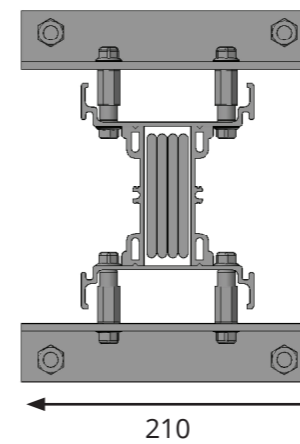

SIDE VIEW

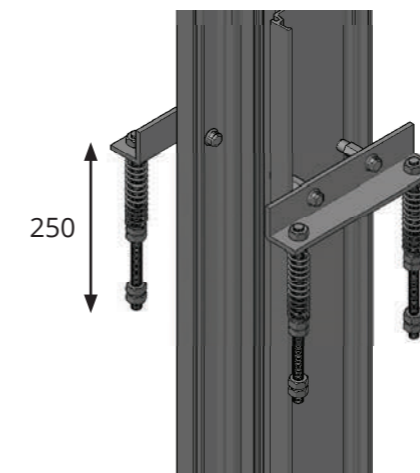

#### SHAFT HANGER KIT

AMR	AMR
HPS04	HPS05
HPS05	HPS06
HPS06	HPS07
HPS08	HPS09
HPS10	HPS13
HPS12	HPS15
HPS14	HPS17
HPS16	HPS21
HPS20	HPS23
HPS25	HPS24
HPS26	HPS22
HPS30	HPS27
HPS32	HPS33
HPS40	HPS36
HPS50	HPS41
	HPS42
	HPS51
	HPS63

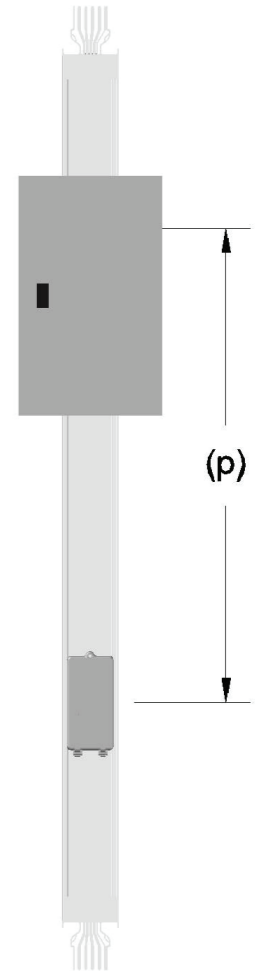

TAP-OFF UNIT	MINIMUM HOLE PITCH
AMR	P (mm)
50A-200A	650
400A	900
600A	1000
800A	1000
1000A	1300
1200A	1300

▶ Please contact us for custom-length modules.

### Wall Hanger Kit

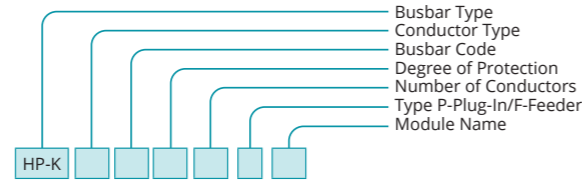

Wall Hanger Kit Horizontal Application	DYA
--	-----

#### SAMPLE ORDER

1600 A Aluminum  
Wall Hanger  
IP 55 4 Conductor

**HP-KA165T2DYA**

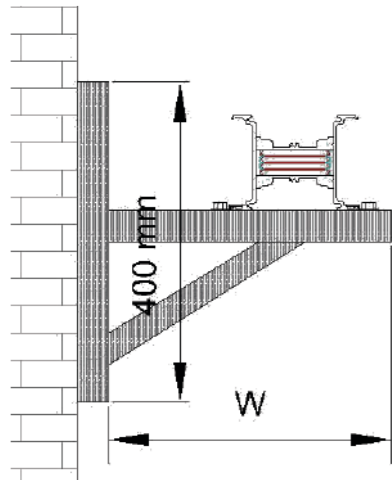

#### WALL HANGER KIT (HORIZONTAL)

AL		CU	
AMR	W (mm)	AMR	W (mm)
400A	307	550A	307
500A	307	650A	307
630A	307	800A	307
800A	322	1000A	322
1000A	347	1250A	337
1250A	377	1350A	347
1350A	392	1600A	377
1600A	427	2000A	407
2000A	467	2250A	427
2500A	724	2500A	467
2500A	804	2000A	414
3000A	584	2500A	464
3200A	624	3300A	524
4000A	704	3600A	554
5000A	942	4000A	584
		4250A	624
		5000A	704
		6300A	942

Wall Hanger Standard (VERTICAL)

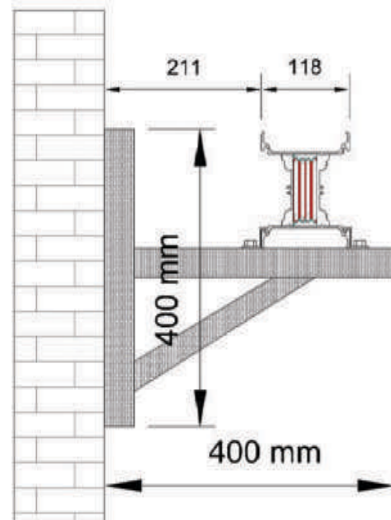

▶ Please contact us for custom-length modules.

### Spring Shaft Hanger Kit

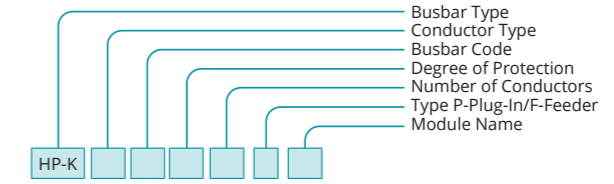

Spring Shaft Hanger Kit	SA
----------------------------	----

#### SAMPLE ORDER

1000 A Aluminum  
Spring Hanger  
IP 55 4 Conductor

**HP-KA105T2SA**

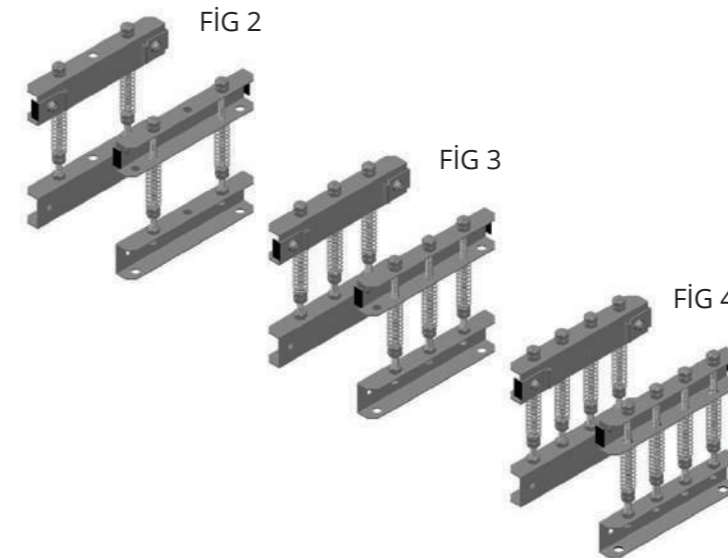

#### SPRING SHAFT HANGER CONNECTION FIGURES

AL		CU	
400A	FIG2	550A	FIG2
500A	FIG2	650A	FIG2
630A	FIG2	800A	FIG2
800A	FIG2	1000A	FIG2
1000A	FIG2	1250A	FIG3
1250A	FIG2	1350A	FIG3
1350A	FIG2	1600A	FIG3
1600A	FIG2	2000A	FIG3
2000A	FIG3	2250A	FIG4
2500A	FIG3	2500A	FIG4
2500A	FIG3	2000A	FIG4
3000A	FIG4	2500A	FIG4
3200A	FIG4	3300A	FIG4
4000A	FIG4	3600A	FIG4
5000A	FIG4	4000A	FIG4
		4250A	FIG4
		5000A	FIG4
		6300A	FIG4

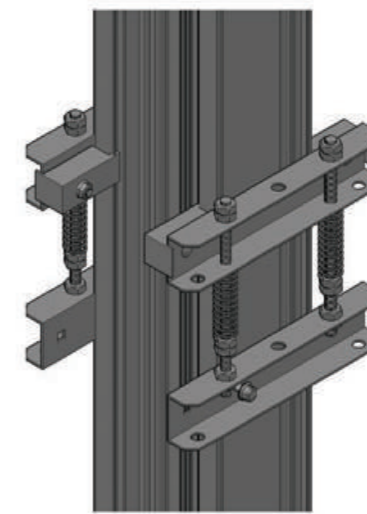

▶ Please contact us for custom-length modules.

### Horizontal Hanger Kit

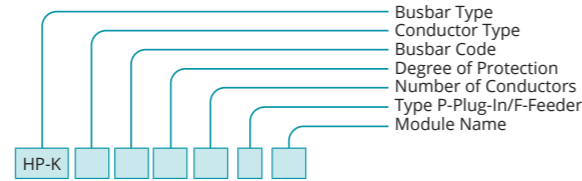
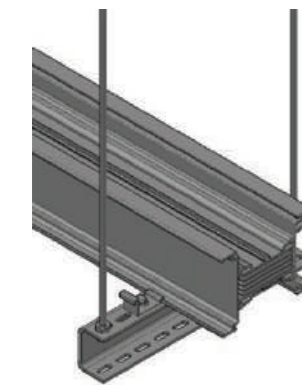
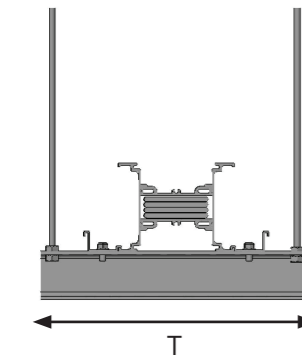
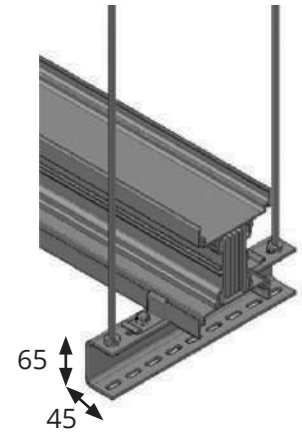
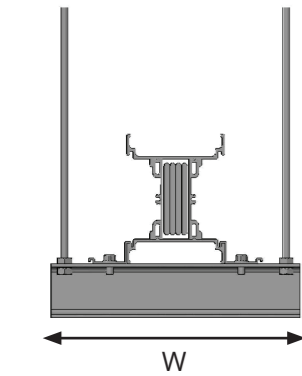

Horizontal Hanger Kit Vertical Application	YUD
--	-----

**SAMPLE ORDER**  
800 A Aluminum  
Horizontal Hanger  
IP 55 4 Conductor  
**HP-KA085T2YUD**

HORIZONTAL HANGER KIT VERTICAL APPLICATION			
AL		CU	
AMR	W	AMR	W
400A	300	550A	300
500A	300	650A	300
630A	300	800A	300
800A	300	1000A	300
1000A	300	1250A	300
1250A	300	1350A	300
1350A	300	1600A	300
1600A	300	2000A	300
2000A	300	2250A	300
2500A	300	2500A	300
2500A	300	2000A	300
3000A	300	2500A	300
3200A	300	3300A	300
4000A	300	3600A	300
5000A	300	4000A	300
		4250A	300
		5000A	300
		6300A	300

Horizontal Hanger Kit Horizontal Application	YUY
--	-----

**SAMPLE ORDER**  
1000 A Aluminum  
Horizontal Hanger  
IP 55 4 Conductor  
**HP-KA105T2YUY**

HORIZONTAL HANGER KIT HORIZONTAL APPLICATION			
AL		CU	
AMR	T	AMR	T
400A	310	550A	310
500A	310	650A	310
630A	310	800A	310
800A	310	1000A	310
1000A	310	1250A	310
1250A	360	1350A	310
1350A	360	1600A	360
1600A	410	2000A	410
2000A	460	2250A	410
2500A	460	2500A	460
2500A	510	2000A	410
3000A	560	2500A	460
3200A	610	3300A	510
4000A	710	3600A	560
5000A	910	4000A	560
		4250A	610
		5000A	710
		6300A	910

▶ Please contact us for custom-length modules.

### Horizontal Hanger Kit (L)

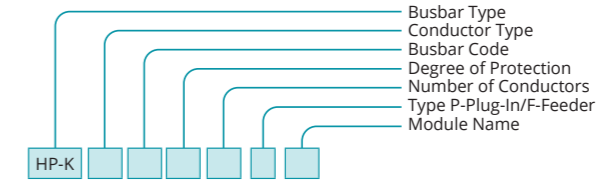
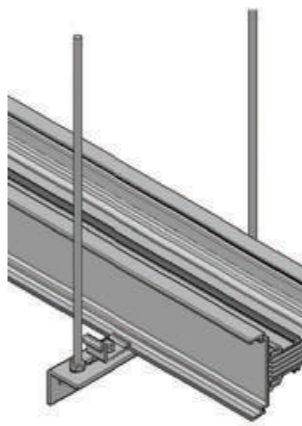
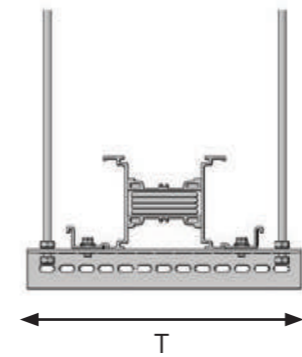
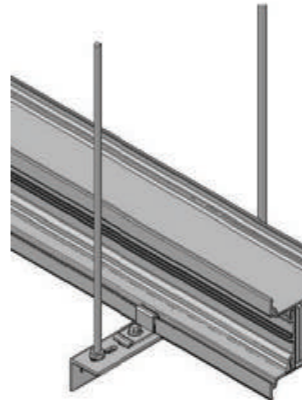
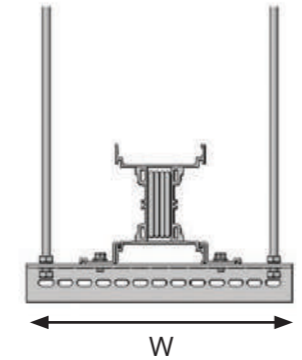

Horizontal Hanger Kit Vertical Application	YLD
--	-----

**SAMPLE ORDER**  
1350 A Aluminum  
Horizontal Bracket Hanger  
IP 55 4 Conductor  
**HP-KA135T2YLD**

HORIZONTAL HANGER KIT VERTICAL APPLICATION			
AL		CU	
AMR	W	AMR	W
400A	300	550A	300
500A	300	650A	300
630A	300	800A	300
800A	300	1000A	300
1000A	300	1250A	300
1250A	300	1350A	300
1350A	300	1600A	300
1600A	300	2000A	300
2000A	300	2250A	300
2500A	300	2500A	300
2500A	300	2000A	300
3000A	300	2500A	300
3200A	300	3300A	300
4000A	300	3600A	300
5000A	300	4000A	300
		4250A	300
		5000A	300
		6300A	300

Horizontal Hanger Kit Horizontal Application	YLY
--	-----

**SAMPLE ORDER**  
1600 A Aluminum  
Horizontal Bracket Hanger  
IP 55 4 Conductor  
**HP-KA165T2YLY**

HORIZONTAL HANGER KIT HORIZONTAL APPLICATION			
AL		CU	
AMR	T	AMR	T
400A	310	550A	310
500A	310	650A	310
630A	310	800A	310
800A	310	1000A	310
1000A	310	1250A	310
1250A	360	1350A	310
1350A	360	1600A	360
1600A	410	2000A	410
2000A	460	2250A	410
2500A	460	2500A	460
2500A	510	2000A	410
3000A	560	2500A	460
3200A	610	3300A	510
4000A	710	3600A	560
5000A	910	4000A	560
		4250A	610
		5000A	710
		6300A	910

▶ Please contact us for custom-length modules.

### ▶ Shaft Wall Hanger Kit

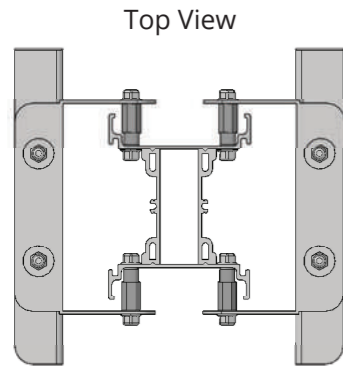
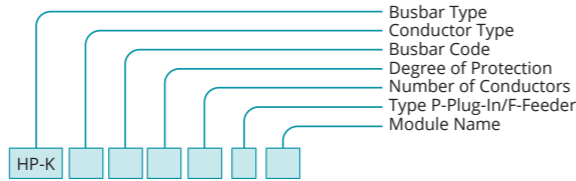

Shaft Wall Hanger Kit	SD
-----------------------	----

**SAMPLE ORDER**  
800 A Aluminum  
Horizontal Hanger  
IP 55 4 Conductor  
**HP-KA085T2SD3**

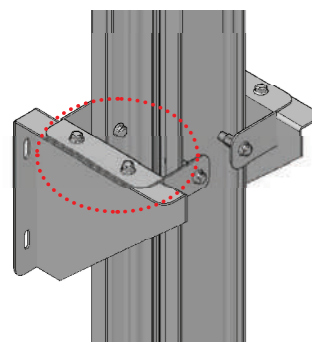

(1) Fixed

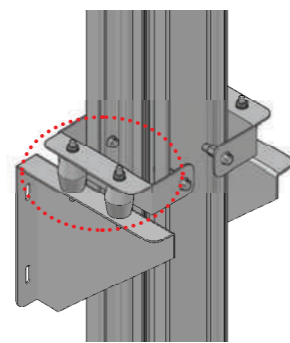

(2) Rubber

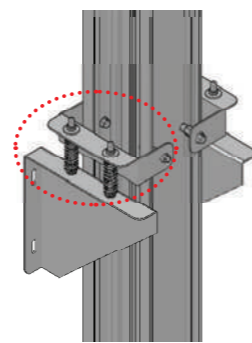

(3) Spring

Shaft Busbar Fittings	SB
-----------------------	----

**SAMPLE ORDER**  
1000 A Aluminum  
Shaft Fittings  
IP 55 4 Conductor  
**HP-KA105T2SB5**

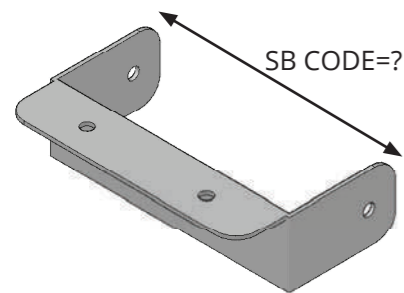

SHAFT FITTINGS (CUSTOM)			
AL		CU	
AMR	KOD	AMR	KOD
400A	SB1	550A	SB1
500A	SB1	650A	SB1
630A	SB1	800A	SB1
800A	SB2	1000A	SB2
1000A	SB3	1250A	SB14
1250A	SB4	1350A	SB3
1350A	SB5	1600A	SB4
1600A	SB6	2000A	SB15
2000A	SB7	2250A	SB6
2500A	SB8	2500A	SB7
2500A	SB9	2000A	SB16
3000A	SB10	2500A	SB17
3200A	SB11	3300A	SB8
4000A	SB12	3600A	SB18
5000A	SB13	4000A	SB10
		4250A	SB11
		5000A	SB12
		6300A	SB13

▶ Please contact us for custom-length modules.

### ▶ Shaft Wall Hanger Kit

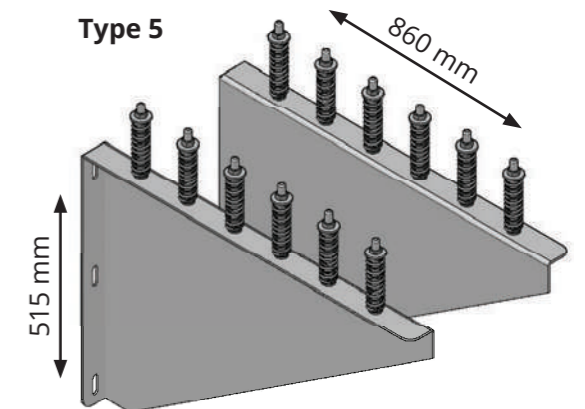
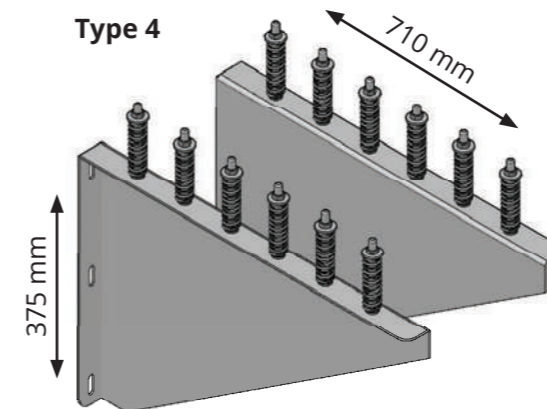
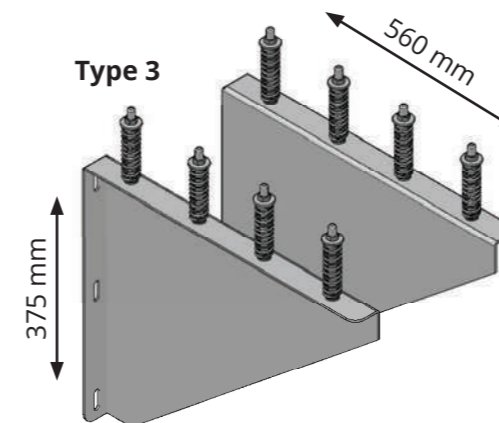
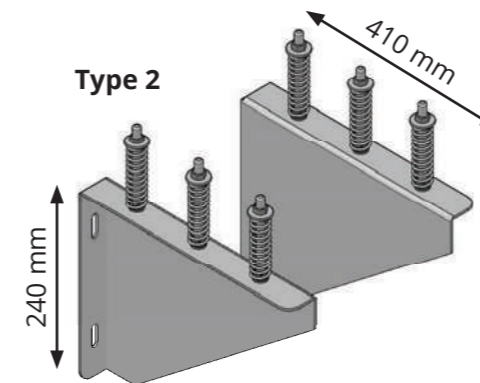
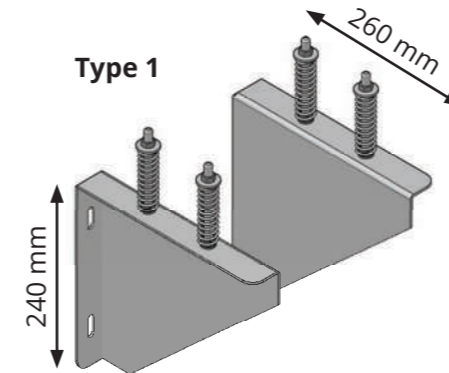
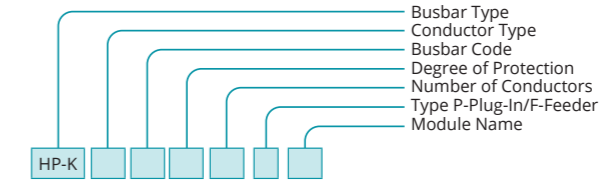

SHAFT WALL HANGER KIT TABLE			
AL		CU	
AMR	TPYE	AMR	TPYE
400A	TYPE1	550A	TYPE1
500A	TYPE1	650A	TYPE1
630A	TYPE1	800A	TYPE1
800A	TYPE1	1000A	TYPE1
1000A	TYPE1	1250A	TYPE1
1250A	TYPE2	1350A	TYPE2
1350A	TYPE2	1600A	TYPE2
1600A	TYPE2	2000A	TYPE2
2000A	TYPE2	2250A	TYPE2
2500A	TYPE2	2500A	TYPE2
2500A	TYPE4	2000A	TYPE2
3000A	TYPE3	2500A	TYPE3
3200A	TYPE3	3300A	TYPE3
4000A	TYPE4	3600A	TYPE3
5000A	TYPE5	4000A	TYPE4
		4250A	TYPE4
		5000A	TYPE4
		6300A	TYPE5

▶ Please contact us for custom-length modules.

TECHNICAL TABLE (HP-K AL)																			
ALUMINUM CONDUCTOR (AL)																			
Rated Current	In	A	400	500	630	800			1000	1250	1350	1600	2000	2500	2500	3000	3200	4000	5000
BUSBAR CODE			HP-KA04	HP-KA05	HP-KA06	HP-KA08			HP-KA10	HP-KA12	HP-KA13	HP-KA16	HP-KA20	HP-KA25	HP-KA252	HP-KA30	HP-KA32	HP-KA40	HP-KA50
Degree of Protection	IP55																		
Standards	IEC 61439-6 TS EN 61439-6 IEC 61439-1 TS EN 61439-1																		
Max. Rated Operational Voltage	Ue	Vac	1000																
Rated Impact Resistance Voltage	Uimp	kV	4																
Rated Frequency	f	Hz	50																
Rated Insulation Voltage	Ui	V	1000	Category IV															
Mechanical Impact Resistance (IK Code)	Plug-in Busbar IK07																		
Measures for the Protection of Humans	Basic Protection (HD 60364-4-41, Article A1)																		
Rated Short-Time Current (1s)	Icw	kA	15	18	25	35			50	50	50	50	100	100	100	100	100	120	120
Rated Peak Withstand Current	Ipk	kA	32,2	32,3	52,6	73,6			105,5	131,5	131,5	175	175	222	175	222	263	263	263
Rated Short-Time Current for Neutral Conductor (1s)	Icw	kA	9,8	9,8	14	20			30,2	37	37	47,6	47,6	61	47,6	61	73	73	73
Rated Peak Withstand Current for Neutral Conductor	Ipk	kA	17	17	30,5	44			64	75,5	75,5	101	101	132,2	101	132,2	159	159	159
Rated Short-Time Current for Protective Circuit (1s)	Icw	kA	9,8	9,8	14	20			30,2	37	37	47,6	47,6	61	47,6	61	73	73	73
Rated Peak Withstand Current for Protective Circuit	Ipk	kA	17	17	30,5	44			64	75,5	75,5	101	101	132,2	101	132,2	159	159	159

TECHNICAL TABLE (HP-K CU)																						
COPPER CONDUCTOR (CU)																						
Rated Current	In	A	550	650	800	1000	1250	1350			1600	2000	2250	2500	2000	2500	3300	3600	4000	4250	5000	6300
BUSBAR CODE			HP-KC05	HP-KC06	HP-KC08	HP-KC10	HP-KC10	HP-KC13			HP-KC16	HP-KC20	HP-KC22	HP-KC25	HP-KC202	HP-KC252	HP-KC33	HP-KC36	HP-KC40	HP-KC42	HP-KC50	HP-KC63
Degree of Protection	IP55																					
Standards	IEC 61439-6 TS EN 61439-6 IEC 61439-1 TS EN 61439-1																					
Max. Rated Operational Voltage	Ue	Vac	1000																			
Rated Impact Resistance Voltage	Uimp	kV	4																			
Rated Frequency	f	Hz	50																			
Rated Insulation Voltage	Ui	V	1000	Category IV																		
Mechanical Impact Resistance (IK Code)	Plug-in Busbar IK07																					
Measures for the Protection of Humans	Basic Protection (HD 60364-4-41, Article A1)																					
Rated Short-Time Current (1s)	Icw	kA	26	26	40	50	50	50			50	100	100	80	70	100	100	100	120	120	120	120
Rated Peak Withstand Current	Ipk	kA	52	52	85	104	132,5	175,5			175,5	175,5	175,5	175,5	155	222	263	263	263	263	263	263
Rated Short-Time Current for Neutral Conductor (1s)	Icw	kA	15,8	15,8	25	32	34	36			50	50	50	50	44	58	70	70	70	70	70	70
Rated Peak Withstand Current for Neutral Conductor	Ipk	kA	30	30	50,5	63,2	75,5	75,5			101	101	101	101	88	132,2	158,5	158,5	158,5	158,5	158,5	158,5
Rated Short-Time Current for Protective Circuit (1s)	Icw	kA	15,8	15,8	25	32	34	36			50	50	50	50	44	58	70	70	70	70	70	70
Rated Peak Withstand Current for Protective Circuit	Ipk	kA	30	30	50,5	63,2	75,5	75,5			101	101	101	101	88	132,2	158,5	158,5	158,5	158,5	158,5	158,5



**1. Operating current (OC) is calculated based on the following formula.**

$$I_b = \frac{P \times F}{\sqrt{3} \times U_e \times \cos \varphi}$$

Parameters to consider

P: Total power of feeding load  
F: Feeding load coefficient

**2. Feeding load coefficient varies by the place of use. It may need to be calculated for each use. Some places of use and coefficients are given in the table below.**

Place of Use:	Number of Users:	Coefficient:
Industrial	1 to 10	0.8-0.9
Industrial	10 to 20	0.7-0.8
Industrial	20 to 40	0.6-0.7
Service	Large Offices	0.7-0.8
Service	Shopping Malls	0.8-0.9

**3. U<sub>e</sub>: Operating Voltage (V)**

Example: Place of Use: Industrial

Number of Users: 18

Uniform power unit: 150kw

Max. Operating voltage 400V

cosφ 0.95

$$I_b = \frac{P \times F}{\sqrt{3} \times U_e \times \cos \varphi}$$

Total power 12x12=144kw 2700000 (W) P

Coefficient: 0.8

$$I_b = \frac{2700000 \times 0,8}{1,73 \times 400 \times 0,95} = 3285 \text{ A}$$

As a manufacturing company, you need to take future power increases into consideration. Accordingly, you can make your busbar safer by a margin of 20%.

3285 A X 1.20 = 3942 A

Current options 4000A AL 4000A CU

**4. The temperature of the place of use must be checked. Busbar conductors are designed for a daily average temperature of 40°C. It may be necessary to upgrade the busbar depending on temperature rise.**

K : Reduction coefficient depending on ambient temperature

Example: (Daily) average temperature: 50°C and

**Busbar conductor is 4000A. For a temperature of 50°C:**

4000A X 0,84=3360 A

**6. If the ambient temperature is 50°C, the conductors should not carry more than 3360A. If a higher current is required, the busbar must be upgraded.**

**7. Depending on voltage drop, calculations are made based on the estimated reference value, and the busbar is selected accordingly. In three-phase systems, voltage drop is calculated based on the following formula, and the following parameters are taken into account.**

$$\Delta V\% = D \times t \times I_b \times L / U_e \times 100$$

Accordingly,

D: Load distribution factor  
It is a coefficient that varies by the direction and point of supply. This multiplier allows for quick calculation.

D=1 Single sided feed and end point output.  
D=0.5 Single sided feed and equal output.  
t : Unit voltage drop value

In the table below (Page 49), values are given in (μV) ampere /mt in respect to Cos φ values.

I<sub>b</sub>: Total of all extra effective loads

L: Total length of the busbar line

U<sub>e</sub> : Supply voltage

Example: For the 4000A busbar, calculations are as follows. (In equal load distribution)

(L) Line length	80 mt
(I <sub>b</sub> ) Effective load	3285A
U <sub>e</sub> : Supply voltage	400V
Cos φ	0,95
(D) Load distribution factor	0,5
(T) Unit voltage drop value	34,17 (V) % <sup>-6</sup>
(ΔV) Maximum permissible voltage drop	4%
$\Delta V\% = D \times t \times I_b \times L / U_e \times 100$	
$\Delta V\% = \frac{0,5 \times 34,17 \times 3285 \times 80 \times 100}{400 \times 10^{-6}} = 1,1 \%$	
The value found is lower than 4%.	

Unit Voltage Drop Values

ALUMINUM	400A	500A	630A	800A	1000A	1250A	1350A	1600A	2000A	2500A	2500A	3000A	3200A	4000A	5000A	Birim: mV/mT			
cosφ=0,70	136,99	136,99	136,99	128,86	115,51	81,48	89,93	59	58,37	40,13	40,13	32,84	32,84	29,5	32,87				
cosφ=0,75	143,01	143,01	143,01	134,47	120,35	84,79	94,02	61,24	60,75	41,75	41,75	34,11	34,11	30,68	33,96				
cosφ=0,80	148,71	148,71	148,71	139,78	124,91	87,88	97,92	63,32	62,97	43,25	43,25	35,29	35,29	31,78	34,95				
cosφ=0,85	153,98	153,98	153,98	144,69	129,07	90,7	96,25	65,12	64,99	44,61	44,61	36,35	36,35	32,78	35,79				
cosφ=0,90	158,61	158,61	158,61	148,98	132,66	93,08	91,55	66,68	66,71	45,76	45,76	37,22	37,22	33,62	36,42				
cosφ=0,95	162,05	162,05	162,05	152,14	135,17	94,67	93,45	67,57	67,85	46,51	46,51	37,75	37,75	34,17	36,65				
cosφ=1	158,64	158,64	158,64	148,78	131,48	91,69	89,24	64,88	65,74	44,98	44,98	36,33	36,33	33,04	34,6				
COPPER	550A	650A	800A	1000A	1250A	1350A	1600A	2000A	2250A	2500A	2000A	2500A	3300A	3600A	4000A		4250A	5000A	6300A
cosφ=0,70	121,59	121,59	121,59	87,66	76,56	76,56	56,12	50,84	50,84	38,63	36,65	38,63	28,87	28,87	23,16		23,16	20,73	20,73
cosφ=0,75	126,69	126,69	126,69	90,51	78,27	78,27	57,08	51,96	51,96	39,6	36,93	39,6	29,68	29,68	23,73	23,73	21,14	21,14	
cosφ=0,80	131,48	131,48	131,48	93,07	79,65	79,65	57,78	52,87	52,87	40,41	37,02	40,41	30,38	30,38	24,22	24,22	21,45	21,45	
cosφ=0,85	135,87	135,87	135,87	95,25	80,6	80,6	58,14	53,49	53,49	41,02	36,85	41,02	30,94	30,94	24,58	24,58	21,64	21,64	
cosφ=0,90	139,64	139,64	139,64	96,85	80,92	80,92	57,97	53,69	53,69	41,33	36,27	41,33	31,28	31,28	24,77	24,77	21,65	21,65	
cosφ=0,95	142,28	142,28	142,28	97,37	80,04	80,04	56,84	53,09	53,09	41,07	34,96	41,07	31,23	31,23	24,61	24,61	21,65	21,65	
cosφ=1	138,4	138,4	138,4	91,69	72,31	72,31	50,17	47,92	47,92	37,54	29,41	37,54	28,89	28,89	22,49	22,49	19,03	19,03	

HP-K TECHNICAL SPECIFICATIONS

- 1) Complies with the standards IEC 61439-6 and TSE 61439-6,
- 2) Accredited and ready for type tests for all stages.
- 3) CE marked.
- 4) ISO 9001 and ISO 14001 certified.
- 5) Production year: 2001.
- 6) Electrical values - insulation voltage: 1000V; ambient temperature: max. 400; max. temperature rise: 95 K.
- 7) Housing is made of 2.7 mm extruded aluminum profile.
- 8) Powder coated (RAL 7038).
- 9) Conductors: Class B Mylar film coating between double layer epoxy coating.
- 10) Conductors: EC-Grade. Conductivity: 34 m/mm2 ohm for Aluminum and 56 m/mm2 ohm for Copper.
- 11) Degree of Protection: IP 55/ IP 65,
- 12) Bolt-On Tap-Off Unit: 1000A,
- 13) Conductor ends are tin plated.

**ELECTRICAL CHARACTERISTIC VALUES**

For frequency 60Hz. the following values are multiplied by 0.83.

**ALUMINUM**

Nominal	Impedance x 10 <sup>-3</sup> Ω/m between phase and neutral			Power Factor %							
	R	X	Z	1	0,9	0,8	0,7	0,6	0,5	0,4	0,3
Current											
400A	6,99	3,9	8,01	9,67	11,1	11	10,6	10,1	9,51	8,81	8,05
500A	6,99	3,9	8,01	9,67	11,1	11	10,6	10,1	9,51	8,81	8,05
630A	6,99	3,9	8,01	9,67	11,1	11	10,6	10,1	9,51	8,81	8,05
800A	6,5	2,31	6,9	11,2	11,2	11,4	10,7	9,94	9,08	8,16	7,18
1000A	5,2	2,07	5,6	10,7	11,5	11,2	10,6	9,91	9,11	8,25	7,33
1250A	3,5	1,72	3,9	8,17	11,3	12	12,2	12,2	12	11,6	11,1
1350A	3,1	1,62	3,5	8,58	11,9	12,7	12,9	12,9	12,7	12,3	11,8
1600A	2,5	1,28	2,9	8,65	9,71	9,57	9,21	8,73	8,16	7,51	6,81
2000A	1,9	0,43	1,95	8,21	8,2	7,68	7,08	6,41	5,71	4,99	4,23
2500A	1,5	0,68	1,65	7,78	8,54	8,34	7,96	7,49	6,94	6,34	5,7
2500A	1,4	0,14	1,45	9,68	9,14	8,33	7,47	6,58	5,68	4,76	3,83
3000A	1,15	0,37	1,21	6,03	6,90	7,74	8,52	9,24	9,87	10,34	9,94
3200A	1,02	0,33	1,08	6,49	7,43	8,32	9,15	9,92	10,58	11,08	10,63
4000A	5,2	2,07	5,6	10,7	11,5	7,68	7,08	6,41	5,71	4,99	4,23
5000A	2,5	1,28	2,9	8,65	9,71	11,4	10,7	9,94	9,08	8,16	7,18

**COPPER**

Nominal	Impedance x 10 <sup>-5</sup> Ω/m between phase and neutral			Power Factor %							
	R	X	Z	1	0,9	0,8	0,7	0,6	0,5	0,4	0,3
Current											
550A	8,91	4,12	9,01	11,1	12,4	12,4	12,7	12,6	12,3	12,9	12,2
650A	8,91	4,12	9,01	11,1	12,4	12,4	12,7	12,6	12,3	12,9	12,2
800A	8,91	4,12	9,01	11,1	12,4	12,4	12,7	12,6	12,3	12,9	12,2
1000A	6,1	2,24	6,5	8,44	8,15	7,68	7,51	7,92	8,01	8,12	7,98
1250A	4,5	2,98	5,4	7,47	8,21	7,41	7,31	7,81	8,13	8,1	7,82
1350A	4,1	1,85	4,5	6,22	8,29	7,12	7,12	7,51	8,53	10,1	8,9
1600A	3,3	1,88	3,8	5,25	8,31	7,01	6,91	7,35	8,51	9,25	9,12
2000A	2,5	1,61	3,01	4,16	8,01	6,98	6,15	7,12	7,03	8,63	10,1
2250A	2	1,13	2,3	3,18	8,11	7,11	6,03	7,09	6,9	7,61	5,72
2500A	1,5	1,08	1,85	2,56	8,61	7,05	6,19	7,38	7,12	6,98	4,02
2000A	1,3	0,74	1,5	2,07	8,55	7,81	6,25	7,49	6,01	5,91	5,51
2500A	1	0,45	1,1	1,52	8,38	7,03	6,12	7,01	5,15	4,51	3,41
3300A	0,80	0,45	0,91	6,92	7,57	8,17	8,69	9,11	9,41	9,48	8,02
3600A	0,62	0,35	0,71	6,71	7,34	7,91	8,42	8,83	9,12	9,18	8,02
4000A	5,2	2,07	5,6	10,7	11,5	8,33	7,47	6,58	5,68	4,76	3,83
4250A	2,5	1,28	2,9	8,65	9,71	7,68	7,08	6,41	5,71	4,99	4,23
5000A	1,4	0,14	1,45	9,68	9,14	9,57	9,21	8,73	8,16	7,51	6,81
6300A	6,5	2,31	6,9	11,2	11,2	11,4	10,7	9,94	9,08	8,16	7,18

DISTANCE BETWEEN TWO BUSBARS

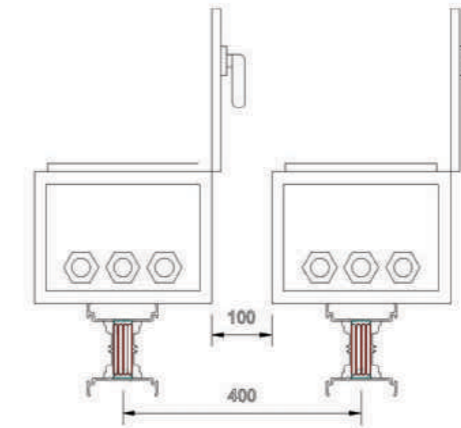

PLACEMENT OF THE BUSBAR INSIDE THE SHAFT

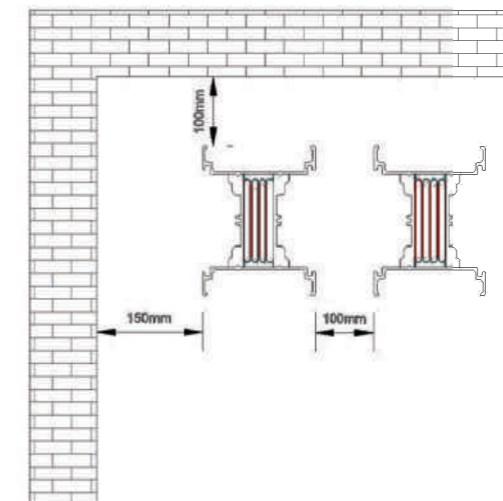
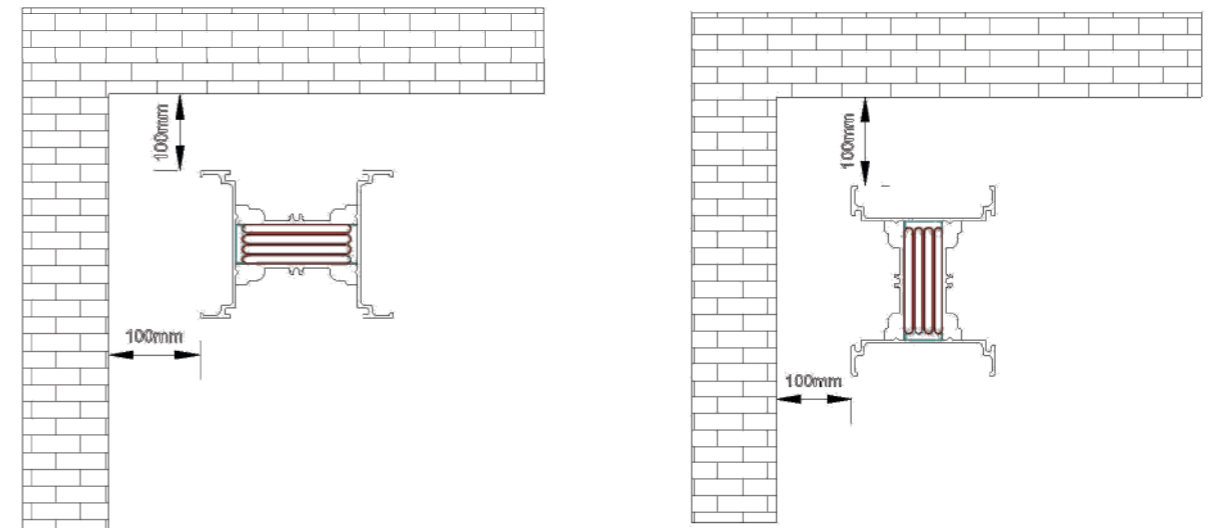

ALUMINUM BUSBAR DIMENSIONS AND WEIGHTS									
Current	BUSBAR MM			EACH PHASE				FEEDER KG	
	W	H	MM	FIG.	3p3w+pe	3p4w+pe			
400A	118	102.5	X	6	X	25	1	5.2	6.2
500A	118	102.5				30	1	6.6	7.5
630A	118	102.5				40	1	7.8	8.5
800A	118	117.5				55	1	9.1	10.1
1000A	118	142.5				80	1	11.2	12.7
1250A	118	172.5				110	1	13.8	15.8
1350A	118	187.5				125	1	15.1	17.4
1600A	118	222.5				160	1	18.2	21
2000A	118	262.5				200	1	21.6	25.2
2500A	118	312.5				250	1	28.4	34.1
2500A	118	329				110	2	27.2	31.1
3000A	118	389				140	2	32.4	37.4
3200A	118	429				160	2	35.8	41.5
4000A	118	509				200	2	42.8	49.9
5000A	118	757.5				200	3	63.8	74.5

COPPER BUSBAR DIMENSIONS AND WEIGHTS									
Current	BUSBAR MM			EACH PHASE				FEEDER KG	
	W	H	MM	FIG.	3p3w+pe	3p4w+pe			
550A	118	102.5	X	6	X	25	1	11.8	12.6
650A	118	102.5				30	1	13.5	15.3
800A	118	102.5				40	1	14.3	16.7
1000A	118	117.5				55	1	18.2	21.4
1250A	118	132.5				70	1	21.9	26
1350A	118	142.5				80	1	24.4	29.1
1600A	118	172.5				95	1	32	38.4
2000A	118	202.5				125	1	39.5	47.8
2250A	118	222.5				160	1	44.5	54
2500A	118	262.5				200	1	54.6	66.4
2000A	118	219				55	2	35.8	42.3
2500A	118	269				80	2	48.4	57.8
3300A	118	329				110	2	63.4	76.4
3600A	118	359				125	2	71	85.7
4000A	118	389				140	2	78.5	95.1
4250A	118	429	160	2	88.5	107.4			
5000A	118	509	200	2	108.7	132.3			
6300A	118	757.5	200	3	167.7	198.1			

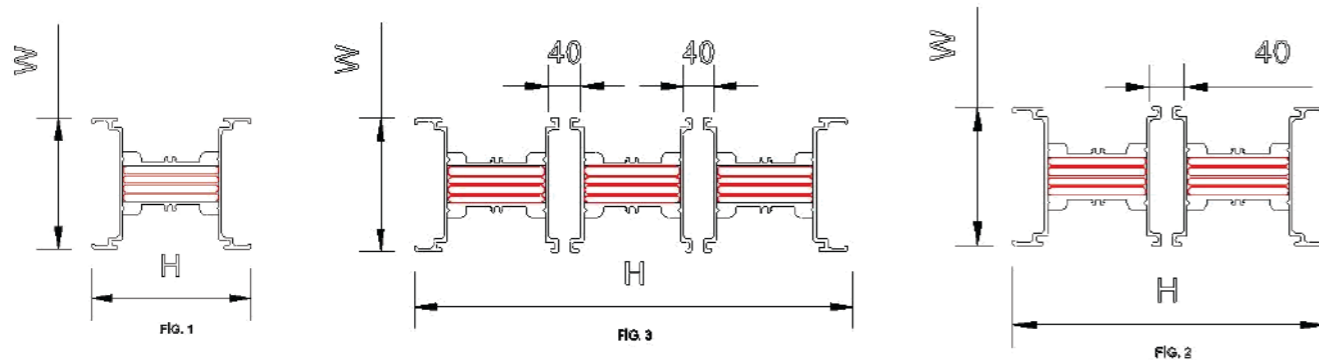

OPTIONAL LENGTH

**MEASUREMENTS FOR JOINING TWO BUSBARS**  
 X: Measured Length (FROM ONE CONNECTOR END TO THE OTHER CONNECTOR END)  
 Example  
 X=1000 mm and Joint Block Spacing= 24 mm  
 1000-24=976 mm  
 Order Dimensions: 930mm

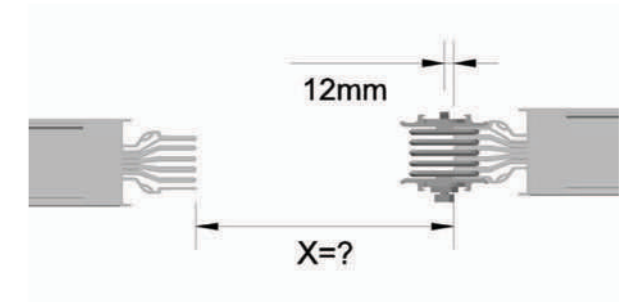

**DOUBLE VERTICAL ELBOW MEASUREMENT**  
 X-X1 must be measured. Joint Block =24mm must be subtracted.

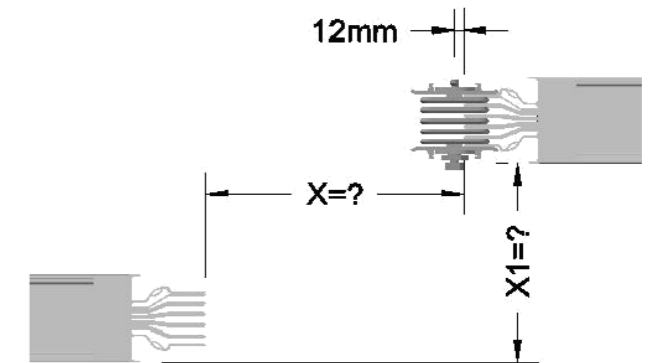

**HORIZONTAL VERTICAL ELBOW MEASUREMENT**  
 X1-X2 must be measured. s=35mm must be subtracted. The order dimensions of Z1-Z2 must be given.

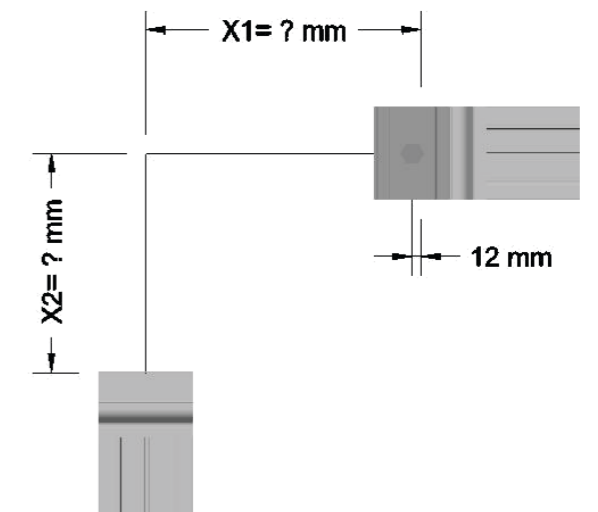

Installation Instructions

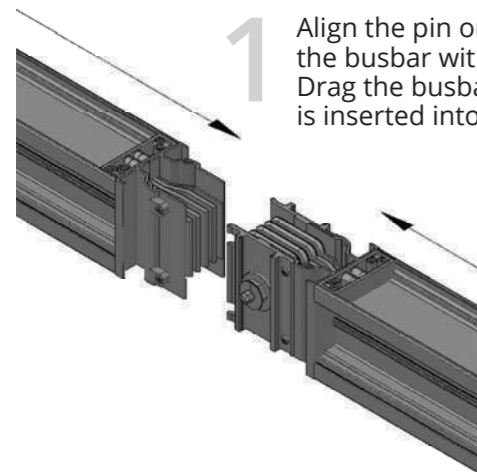

1 Align the pin on the joint of the busbar with the pin hole. Drag the busbar until the pin is inserted into the pin hole.

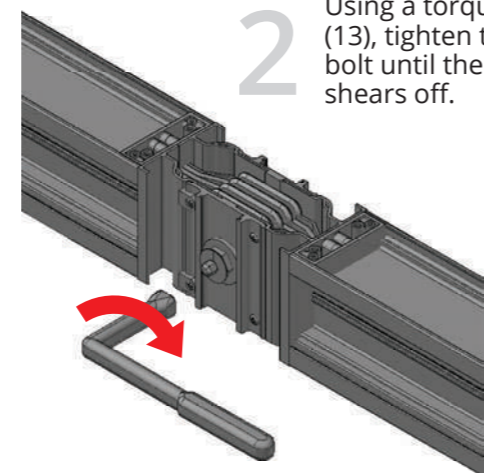

2 Using a torque wrench (13), tighten the shear bolt until the head shears off.

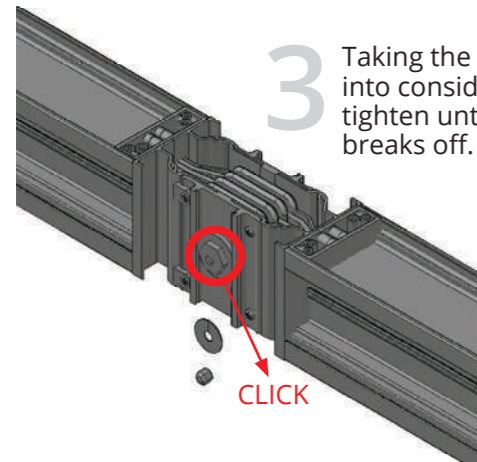

3 Taking the torque value into consideration, tighten until the washer breaks off.

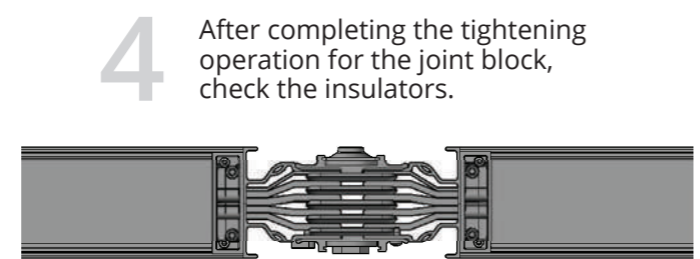

4 After completing the tightening operation for the joint block, check the insulators.

JOINT BLOCK TORQUE VALUE:  
60 lbft (80 Nm)

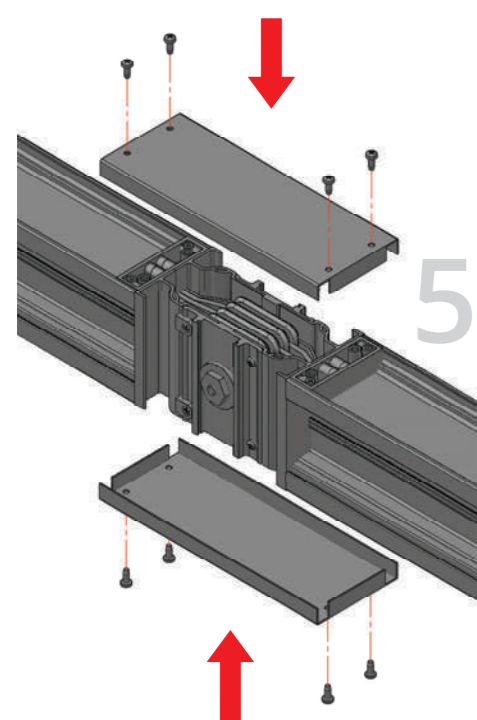

5 Align the joint covers with the centering holes on the busbar. Then, screw the joint covers down to the busbar.

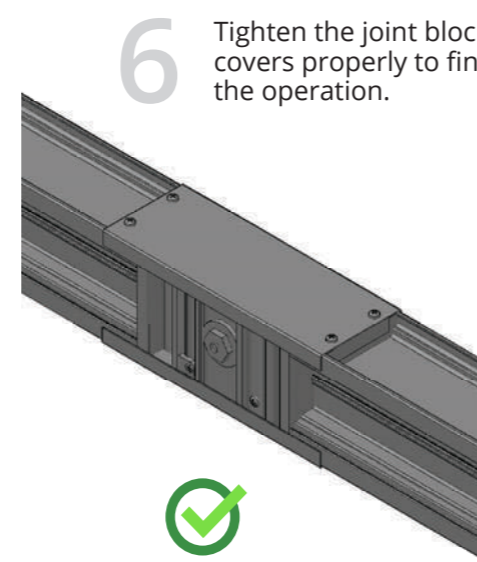

6 Tighten the joint block covers properly to finalize the operation.

▶ Please contact us for custom-length modules.

Tap-Off Unit Installation

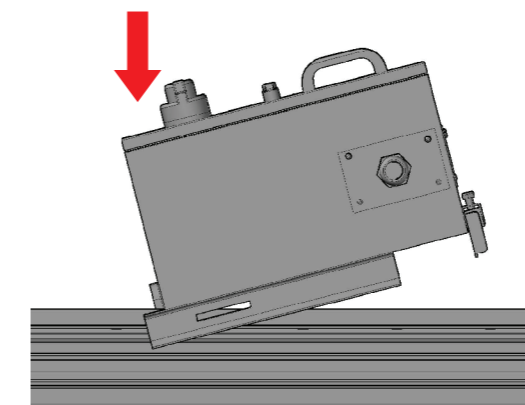

1 Attach the tap-off unit to the housing, paying attention to the hook on the bottom opening of the tap-off unit.

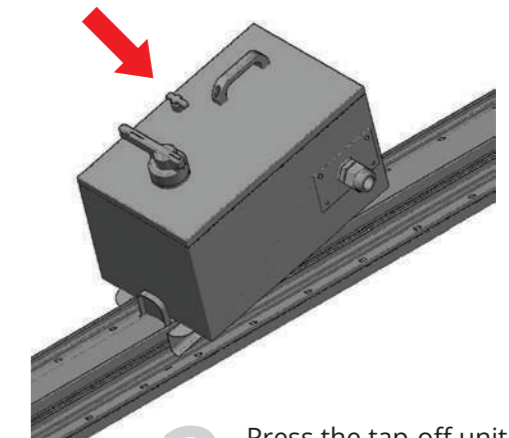

2 Press the tap-off unit down so that it fits into the busbar.

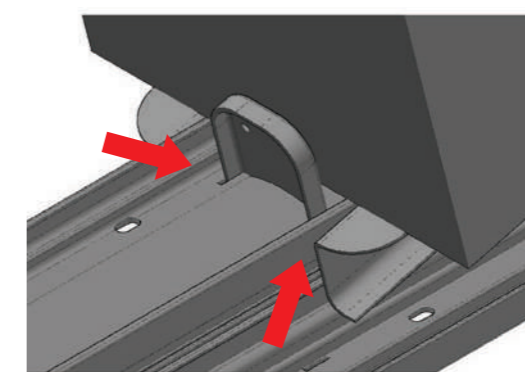

3 Check to see if the tap-off unit is hooked up to the busbar housing.

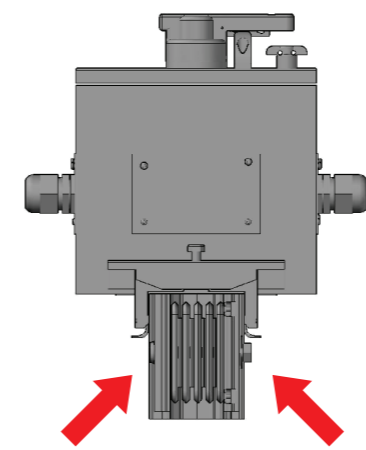

4 Screw the tap-off unit onto the busbar housing with the help of the clamping system.

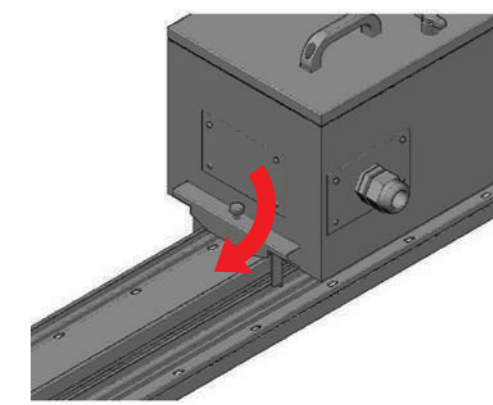

5 Tighten the clamp to fix the unit on the housing.

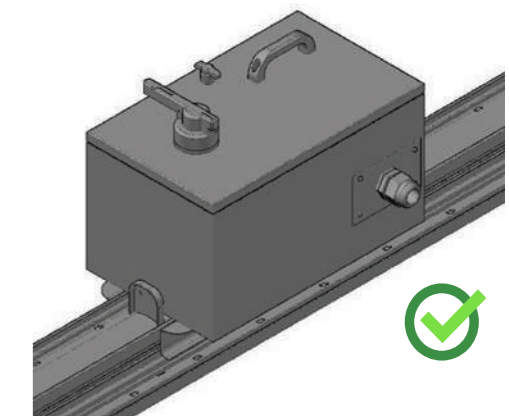

6 Turn on the tap-off unit by means of the special mechanism. Cover the tap-off unit when the mechanism is OFF and power up when it is ON.

NOTE: For safety reasons, when the mechanism is ON, the tap-off unit cannot be uncovered.

▶ Please contact us for custom-length modules.

► Declaration

► Certificates

EC DECLARATION OF CONFORMITY

**Product Group** HP-K Busbar Power Distribution Systems

**Manufacturer** DTM Elektroteknik San. ve Tic. A.Ş.  
Çatalmeşe mah.Sultansuyu cad. No:129  
34794 Çekmeköy / İstanbul

We hereby confirm that the above-stated product/product group manufactured in DTM's Plants is in conformity with the following standards and directives.

**Standard**  
**TS EN 61439-6**  
Low-voltage switchgear and control gear assemblies  
Part 2: Busbar trunking systems (busways)

**EC Directive**  
(2006/95/EC) "Directive relating to electrical equipment designed for use within certain voltage limits"

**Date**  
15.01.2015

DTM Elektroteknik A.Ş.  
*[Signature]*

**DTM Elektroteknik San. Tic. A.Ş.**  
Çatalmeşe Mah. Sultansuyu Cad. No:129 34794 Çekmeköy /İstanbul  
Phone: +90(216) 429 51 74 • www.dtmbusbar.com







## Elektrotechnik A.Ş

📍 Alemdağ Sultansuyu Cad.  
No:129 Çekmeköy 34794  
İstanbul / Türkiye

☎ +90 216 429 51 74 (Pbx)

📠 +90 216 429 47 88

✉ info@dtmbusbar.com

🌐 [www.dtmbusbar.com](http://www.dtmbusbar.com)